





Official Website



GoodWe Technologies Co., Ltd.

 No. 90 Zijin Rd., New District, Suzhou, 215011, China

 www.goodwe.com

 service@goodwe.com

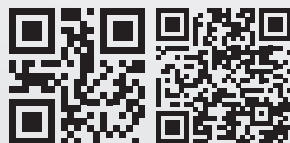

340-00717-00 Local Contacts

User Manual













Grid-Tied PV Inverter

MT G2 Series

V1.0-2022-01-28

1 Symbols	01
2 Safety Measures & Warning	02
3 Product Introduction	04
3.1 Intended Usage	04
3.2 Inverter Overview	05
3.3 Technical Description	07
3.4 Package	08
4 Installation	09
4.1 Mounting Instructions	09
4.2 Equipment Installation	09
4.3 Electrical Connection	11
4.4 Communication Connection	15
5 System Operation	20
5.1 LCD Panel and LED	20
5.2 User Interface Introduction	21
5.3 System Configuration	24
5.4 Wi-Fi Reset & Wi-Fi Reload	28
5.5 Setting Inverter Parameters via App	29
5.6 Monitoring via SEMS Portal	29
5.7 Special Adjustable Setpoints	29
5.8 Power Limit Setting	30
5.9 Error Message	31
6 Troubleshooting	32
7 Technical Parameters & Block Diagram	34
7.1 Technical Parameters	34
7.2 Block Diagram	41
8 Maintenance	45
8.1 Clearing the FAN	45
8.2 (Optional) Checking the DC Switch	45
8.3 Turn On / Off the Inverter	47
8.4 Checking The Electrical Connection	47
8.5 Fuse Replacement	47

1 Symbols

	Failure to observe warnings indicated in this manual may result in injury.
	Recyclable materials
	Danger of high voltage & electric shock
	This side up - The package must always have the arrows point up
	Don't touch, hot surface!
	No more than four (4) identical packages be stacked on each other.
	Special disposal instructions
	Fragile
	Keep Dry
	Refer to operation instructions
	Wait at least 5 min after disconnecting the inverter before touching internal parts
	CE mark.

2 Safety Measures & Warning

This manual contains important instructions for the MT series of inverter which must be followed during installation and maintenance.

The MT series includes four MPPTs and a Three-Phase solar inverter without transformer which consists of GW30KLV-MT / GW35KLV-MT / GW50KLV-MT / GW50KN-MT / GW50KBF-MT / GW50KBF-MT-KR / GW60KBF-MT-KR / GW60KN-MT / GW60KBF-MT / GW75KBF-MT / GW70KHV-MT / GW75K-MT / GW80KHV-MT / GW80K-MT and GW80KBF-MT model types.

MT Series have been designed and tested strictly according to international safety regulations. Because these are electrical and electronic components, related safety instructions must be complied with during installation, and commissioning. Improper operation will cause serious harm to:

1. The life and well-being of the operators or third parties.
2. The inverter and other properties that belong to the operator or a third party.

The following safety instructions must be read and adhered to prior to any work and at all times.. All detailed work-related safety warnings and notes will be specified at the critical points in corresponding chapters. All installation and electrical work must be performed only by qualified personnel. These personnel must meet the standards as stated below:

- Been specially trained and licensed;
- Have thoroughly read and understood all related documents.
- Already familiar with safety requirements of electrical components and systems.

The inverter must be installed and maintained by professionals in compliance with local electrical standards, regulations and the requirements of local power authorities or companies.

- Improper handling of the device poses a risk of injury.
- Always follow the instructions contained in the manual when moving or positioning the inverter.
- The weight of the equipment can cause injuries, serious wounds or bruises if improperly handled.
- Please install equipment where it is out of reach of children.
- Before installing and maintaining the inverter, it is crucial to make certain that the inverter is not electrically connected.
- Before maintaining the inverter, disconnect the connection between the AC grid and the inverter first. Then disconnect the connection between the DC input and the inverter, the operator should wait at least 5 min after the disconnection in case of electric shock.
- All cables must be firmly attached, undamaged, properly insulated, and adequately dimensioned.
- The temperature of some parts of the inverter may exceed 60 °C during operation. To avoid being burned, do not touch the inverter during operation. Let it cool down before touching it.

- Without permission, opening of the inverter's front cover is not allowed. Users should not touch / replace any components of the inverter except the DC / AC connectors. The manufacturer assumes no responsibility for any damage to inverter or person caused by improper operations.
- Static electricity may damage electronic components. Appropriate measures must be adopted to prevent such damage to the inverter. Otherwise, the warranty will be voided.
- Ensure that the output voltage of the proposed PV array is lower than the maximum rated input voltage of the inverter; otherwise the inverter may be damaged and the warranty will be annulled.
- If the equipment is used in a manner not specified by the manufacturer, the protection provided by the equipment may be impaired.
- When exposed to sunlight, the PV array will generate very high voltage, which can cause an electrical shock hazard. Please strictly follow the instructions we have provided.
- PV modules should have an IEC61730 class-A rating.
- Prohibit inserting or pulling the AC or DC terminals when the inverter is working. Otherwise the inverter will be destroyed.

Only DC connectors provided by the manufacturer are permitted for use. Otherwise the inverter may be damaged and the warranty will be voided.

- The inverter can exclude the possibility of DC residual currents to 6 mA in the system, where an external RCD is required in addition to the built-in RCMU, and a type-A RCD must be used to avoid tripping.
- The default photovoltaic module is not grounded.
- If there are more than 3 PV strings on the input side, an additional fuse installation will be required.



The IP65 machine is completely sealed until use. Please install it within one day after unpacking, otherwise please block the unconnected port and do not open it to ensure that the machine is not exposed to water, moisture and dust.

To our inverter product, GOODWE provides a standard manufacturer's warranty, which comes with the product and a prepaid warranty extension solution to our customer. You can find the details about the terms and solutions from the below link.

<https://en.goodwe.com/warranty.asp>

3 Product Introduction

3.1 Intended Usage

The MT series is a four-MPPT, three-phase transformer-less grid-connected inverter, which is a crucial unit between the PV string and the utility grid in the PV power system.

The inverter is dedicated to converting DC generated by the PV module into AC, which conforms to parameters of the local utility grid, feeding it into the utility grid. The intended usage of the inverter is illustrated in the below figure.

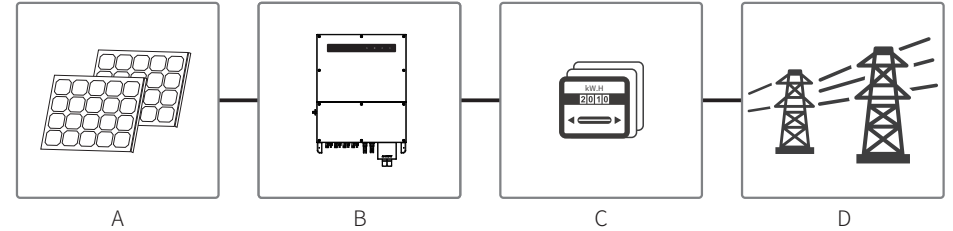

The reason why the inverter cannot be connected to the PV module is that the positive or negative terminal should be grounded, except when a transformer is used between the inverter and the grid.

Item	Description	Note
A	PV string	Monocrystalline silicon, polycrystalline silicon and others.
B	Inverter	MT Series
C	Meter device	Meter cupboard with distributed generation system
D	Utility grid	TN-S, TN-C, TN-C-S, TT, IT (different model types with different types of utility grid as below)

MT series GW30KLV-MT / GW35KLV-MT / GW50KLV-MT / GW50KN-MT / GW50KBF-MT-KR / GW60KBF-MT-KR / GW60KN-MTV / GW50KBF-MT / GW60KBF-MT / GW75K-MT / GW80K-MT support four different types of grid.

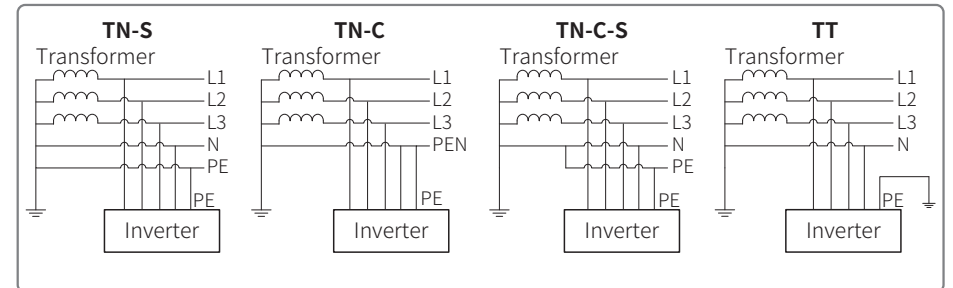

Note: For a TT-grid structure, the RMS voltage between the neutral wire and the earth wire must be less than 20V.

GW70KHV-MT / GW80KHV-MT and GW80KBF-MT support the IT grid type. Refer to the below figure.

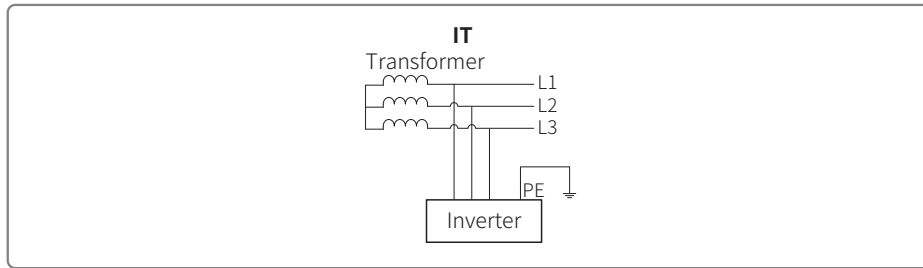

3.2 Inverter Overview

MT series inverter illustration.

Note: Image shown here is for reference only; actual product you receive may be different.

The number of strings per MPPT is different. Refer to the Technical Specification to check more details.

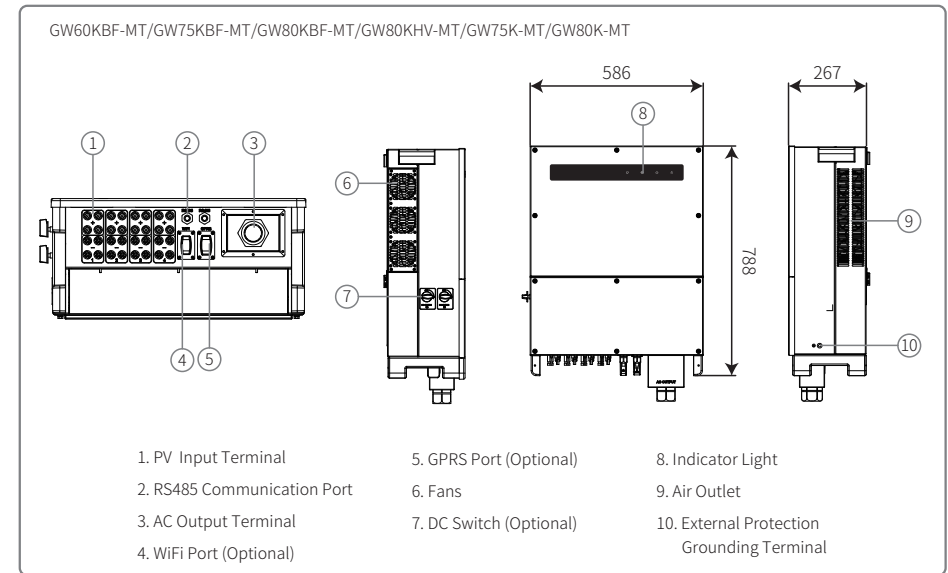
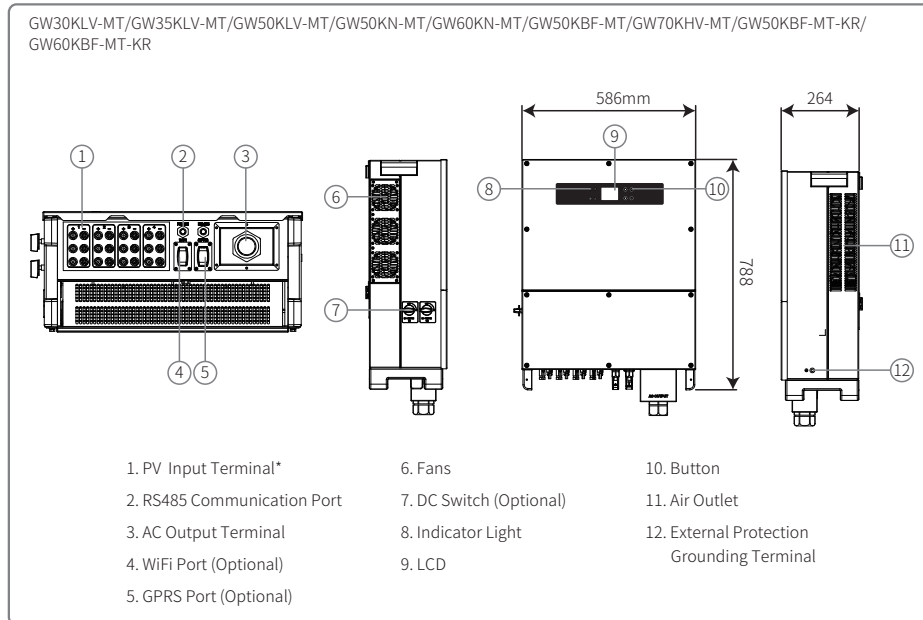

Item	Name	Description
1	PV Input Terminal	For DC cable connection
2	RS485 Communication Port	For RS485 communication cable connection
3	AC Output Terminal	For AC cable connection
4	Wi-Fi Port (Optional)	For Wi-Fi module connection
5	GPRS Port (Optional)	For GPRS module connection
6	Fans	There are six fans to perform controlled force-air cooling.
7	DC Switch (Optional)	During normal operation, it is in the 'on' state; it can shut down the inverter after it is disconnected from the grid at the AC breaker.
8	Indicator light	Display the state of the inverter
9	LCD	Inverter operation data viewing and parameter configuration. The LCD is equipped in some models only.
10	Button	For configuration and viewing parameters.
11	Air Outlet	Exit of hot air during the inverter operation.
12	External Protection Grounding Terminal	Second protection earth terminals as specified in EN50178.

3.3 Technical Description

3.3.1 Principle Description

PV string voltage is transmitted to DC BUS via BOOST circuit.

The MT series is equipped with four MPPTs for four DC inputs to ensure that the maximum power is utilized even in different PV installation configurations.

DC / AC converter circuit converts DC power into AC power, which can be fed into the utility grid. Protective circuits are designed to protect both the inverter's safety and human safety.

DC switch is integrated for safe disconnection of DC input. The inverter provides a standard interface RS485 and Wi-Fi (optional) for communication. Inverters also provide a running recode data display and parameter configuration via LCD panel or App.

Please refer to Chapter 6.2 to check the main block diagram.

3.3.2 Function Description

Inverter functions can be grouped as follows:

- Conversion function
Inverter converts DC power into ac power, which conforms to the grid requirement of its installation country.
- Data storage and display
Inverter stores the running information and fault records, displaying them on the LCD screen or App.
- Parameter configuration
Inverter provides various parameter configurations for optional operation.
- Communication interface
Inverter provides USB,Wi-Fi(optional) and standard RS485 communications interface.
- Protection functions
 - >Insulation resistance to ground surveillance
 - >Input voltage monitor
 - >Residual current monitoring unit
 - >Anti-islanding protection
 - >PV array string fault monitoring
 - >DC fuse
 - >DC switch
 - >DC SPD
 - >AC SPD
 - >SPD fault monitoring
 - >AC over current protection
 - >Insulation monitoring

3.4 Package

The unit is thoroughly tested and strictly inspected before delivery. Damage may occur during shipping.

1. Check the package for any visible damage upon receipt.
2. Check the inner contents for damage after unpacking.
3. Check the package list below:

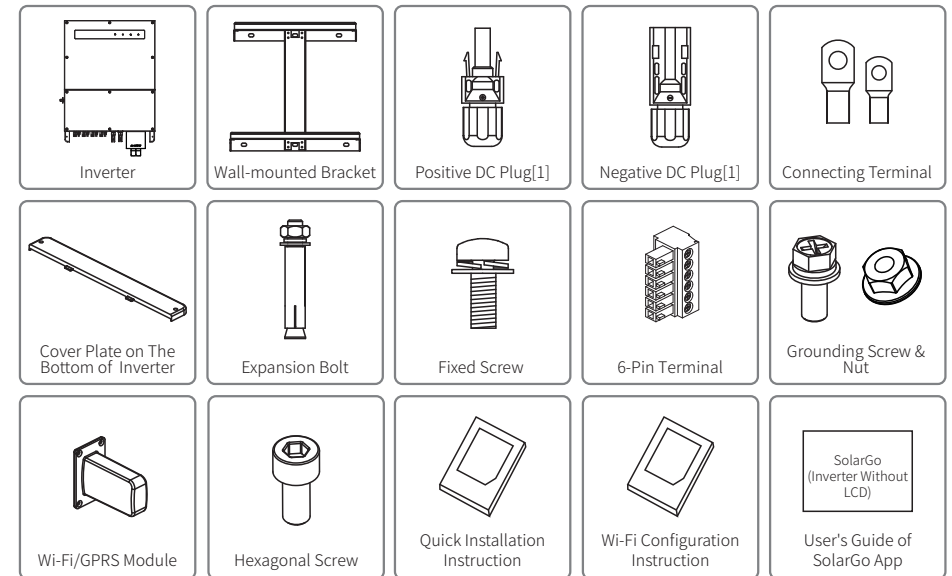

[1]Positive & Negative DC plug:

GW50KBF-MT-KR / GW60KBF-MT-KR / GW50KBF-MT 8 pairs.

GW30KLV-MT / GW50KN-MT 10pairs.

GW35KLV-MT / GW60KN-MT / GW60KBF-MT / GW70KHV-MT / GW80KBF-MT 12 pairs.

GW50KLV-MT / GW75K-MT / GW80KHV-MT / GW80K-MT 16 pairs.

4 Installation

4.1 Mounting Instructions

1. To achieve optimal performance, the ambient temperature should be lower than 45°C.
2. For easy maintenance, we suggest installing the inverter at eye level.
3. Inverters should not be installed near flammable or explosive items. Strong electro-magnetic forces should be kept away from installation site.
4. Product label and warning symbols should be placed at a location that is easy to see / read by the users.
5. Ensure to install the inverter at a place where it is protected from direct sunlight, rain and snow.

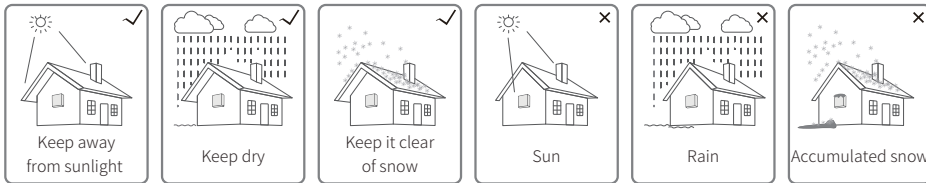

4.2 Equipment Installation

4.2.1 Select the Installation Location

1. Take the bearing capacity of the wall into account. The wall (e.g. concrete and metal) should be strong enough to hold the weight of the inverter over a long period of time.
2. Install the unit where it is accessible to service or provide an electrical connection.
3. Do not install the unit on the wall containing or housing flammable materials.
4. Ensure the installation location is well ventilated.
5. Inverters should not be installed near flammable or explosive items. Any strong electro-magnetic forces should be kept away from the installation site.
6. Install the unit at eye level for convenient operation and maintenance.
7. Install the unit vertically or tilted backwards of no more than 15°, no lateral tilt is allowed. Wiring area should face downwards. Horizontal installation requires more than 250mm elevation.

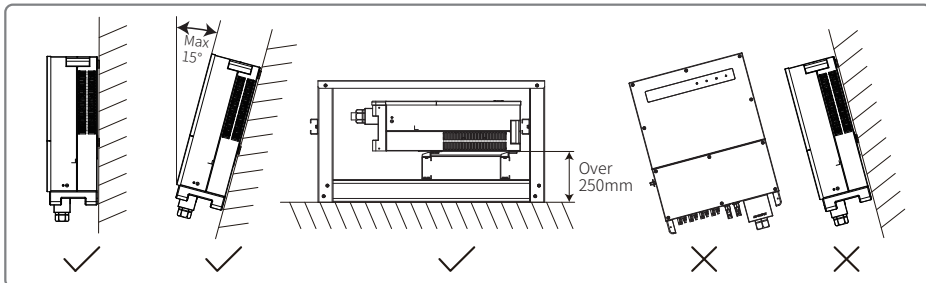

To ensure heat dissipation and convenient disassembly, the minimum clearance around the inverter should not be less than the following values:

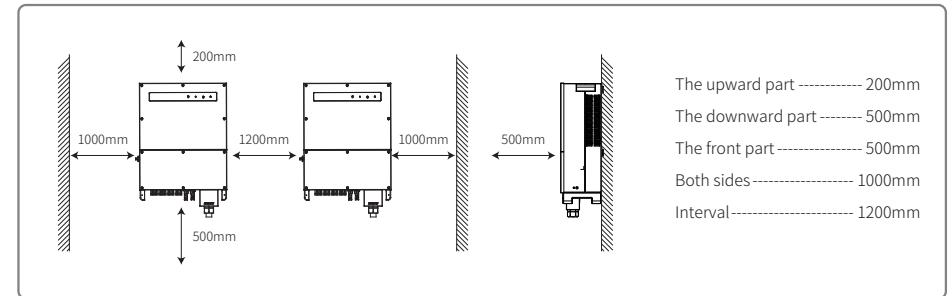

4.2.2 Transport And Mounting Procedure

1. Two operators are required when moving the inverter to hold the handle and arm-brace respectively.
2. Use the wall-mounted bracket as a template and drill 6 holes on the wall: 13 mm diameter and 65 mm deep.
3. Fix the wall-mounted bracket on the wall with six expansion bolts from the accessory bag.
4. Carry the inverter with the handles on both sides of the inverter.
5. Place the inverter on the wall-mounted bracket as illustrated.

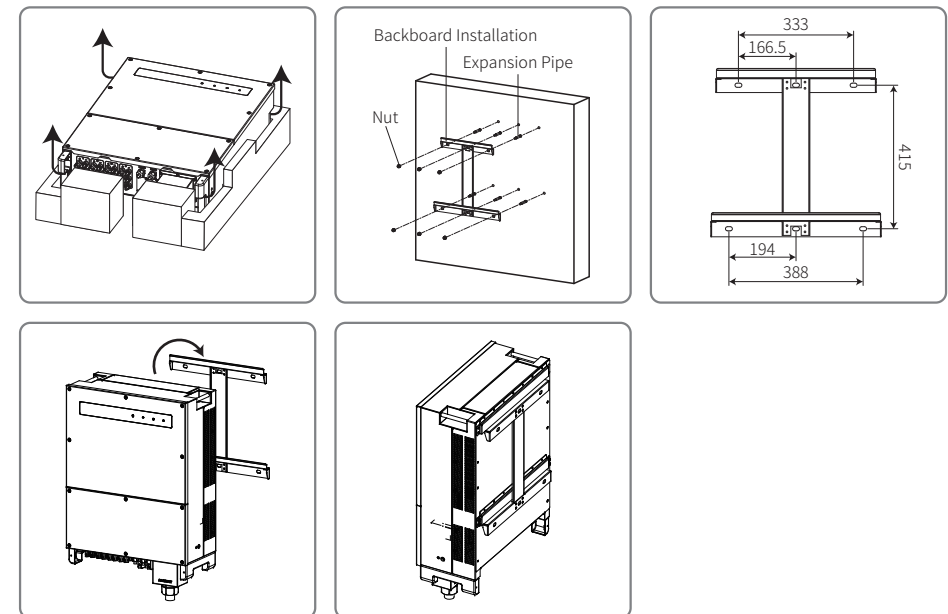

4.2.3 Schematic of Cover Dismantling and Installation Steps

1. Dismantle the downside cover.
(Tool: external hexagonal screwdriver)

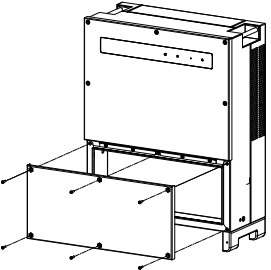

2. Electrical installation.

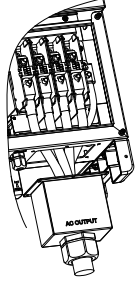

3. Assemble bottom-side cover.
(Tool: hex button. Twisting Force: 2 N.m)

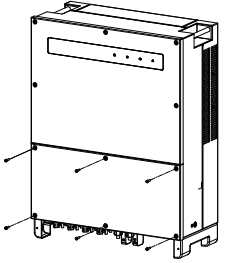

4. Assemble downside cover.
(Material: M5 inner-hexagon screws. Tool: hex button)

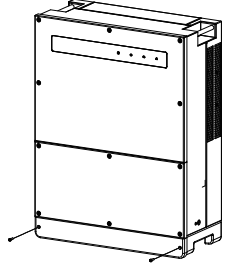

4.3 Electrical Connection

4.3.1 Connection to Grid (AC Side Connection)

1. Measure the voltage and frequency of grid-connected access point, and ensure it is in accordance with the grid-connected standard of the inverter.
2. It is recommended to add a breaker or fuse to the AC side. The specification should be more than 1.25 times rating of the AC output current.
3. The PE line of the inverter should be connected to the earth, ensure that the impedance between the neutral wire and earth wire is less than 10 Ω.
4. Disconnect the breaker or fuse between the inverter and the utility.
5. Connect the inverter to the grid. The wiring installation method on the AC output side is shown as below:
6. Fix (Torque: 6-8 N.m) the connector of the AC cable to the corresponding terminals.

7. Neutral conductor shall be blue; line conductor shall be black or brown (preferred); protective earth bonding line shall be yellow-green.
8. The AC line construction shall be such that if the cord should slip from its anchorage, placing a strain on conductors, the protective earthing conductor will be the last to take the strain. Ensure the PE line is longer than L and N.

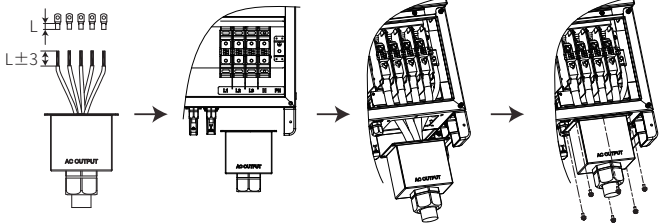

Connect the line to the terminal Tighten the nut Tighten the screws

- L1 ---- Live Wire 1
- L2 ---- Live Wire 2
- L3 ---- Live Wire 3
- N ---- Neutral Wire
- ⊕ ---- Earth Wire



Note: It is not necessary to connect Neutral wire to the inverter of GW30KLV-MT / GW35KLV-MT / GW50KN-MT / GW60KN-MT / GW75K-MT / GW80K-MT products. Please select Delta grid on the panel or SolarGo App, otherwise connect neutral wire to them. Do not connect the neutral wire to the inverter of GW70KHV-MT, GW80KHV-MT and GW80KBF-MT products.

AC cable illustration :

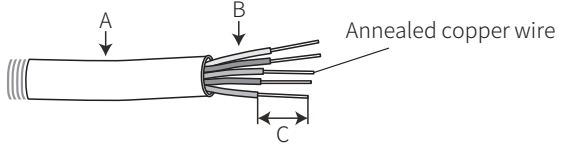

Grade	Description	Value
A	O.D	30~38mm
B	Section area of conduction material	25~95mm ²
C	Length of bare wire	According to the terminal length

4.3.2 AC Circuit Breaker and Residual Current Protection Device

An independent three or four pole circuit-breakers for each inverter must be installed at the output side to ensure that the inverter can be safely disconnected from the grid.

The output current of GW30KLV-MT / GW50KN-MT is 80A. Thus we recommend that the nominal current of the AC breaker be 100 A. The output current of GW35KLV-MT / GW50KBF-MT / GW50KBF-MT-KR / GW60KN-MT / GW60KBF-MT / GW60KBF-MT-KR / GW70KHV-MT / GW80KHV-MT and GW80KBF-MT is 90A. Thus, we recommend that the nominal current of the AC breaker be 120A.

The output current of GW50KLV-MT / GW50KLV-MT / GW80K-MT is 133A. Thus, we recommend that the nominal current of the AC breaker should be more than 160A.



Note: It is not allowed for several inverter to use the same circuit breaker. Connecting loads between the inverter and circuit breaker is also not allowed

The internal integrated residual current detection device (RCD) of the inverter can detect external leakage-current in real time. When the detected leakage current value exceeds the limit value, the inverter will be disconnected from the grid immediately. If an external RCD is installed, a type A RCD must be used to avoid tripping.

Inverter model	Recommended RCD specifications
GW30KLV-MT, GW35KLV-MT, GW50KLV-MT, GW50KN-MT, GW60KN-MT, GW50KBF-MT, GW60KBF-MT, GW75KBF-MT, GW80KBF-MT, GW70KHV-MT, GW80KHV-MT, GW75K-MT, GW80K-MT, GW50KBF-MT-KR, GW60KBF-MT-KR	500mA

4.3.3 Earth Terminal Connection

The inverter is equipped with an earth terminal, per the requirement of EN 50178.

All non-current carrying exposed metal parts of the equipment and other enclosures of the PV power system must be grounded.

Please connect 'PE' cable to ground.

1. Strip the wire insulation sheet to a suitable length using a wire stripper, illustrated below.

Section area of AC cable (S)	Section area of PE cable	Note
$S > 16\text{mm}^2$	16mm ²	Only applicable when the material of PE wire and L wire is the same. If the material is different, please select according to the equivalent resistance of the PE wire.
$S \leq 35\text{mm}^2$	16mm ²	
$S > 35\text{mm}^2$	S/2	

2. Insert the stripped wire into the terminal and compress it tightly by crimping pliers.

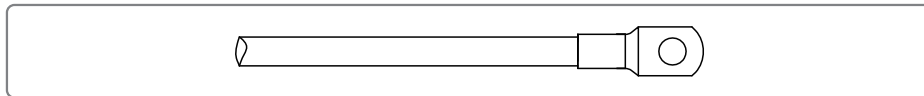

3. Fix the earth wire on the machine.

NO.	Name	Explanation
A	Cold-pressed terminal	
B	Screw	M8*20
C	Yellow and green line	The maximum is 25mm ²

4. To improve the corrosion resistance of the terminal, we recommended to applying silica gel to the earth terminal for corrosion resistance after the grounding cable assembly is completed.

4.3.4 Connecting Inverter to PV Panel



Caution

1. Ensure the DC switch is turned off before connecting PV string to the inverter.
2. Ensure PV string polarity confirms with DC connector. Otherwise, it will cause damage to inverter.
3. Ensure the maximum open circuit voltage (Voc) of each PV string does not exceed the maximum input voltage of the inverter under any circumstances (1100V).
4. Ensure that the maximum short circuit current of each DC input is less than the inverter allowable limit.
5. Do not connect positive or negative poles of PV string to earth (PE terminal). Otherwise, it will destroy the inverter.
6. Positive cable should be red; negative cable should be black.
7. The minimum insulation resistance to ground of the PV panels must exceed 33.3kΩ (R= 1000/30 mA), there is a risk of shock hazard if the requirement of minimum resistance is not met.
8. The MT series has four PV input areas: PV1 input, PV2 input, PV3 input, PV4 input. Each has an MPP tracker. The four PV inputs work independently. Therefore, the four PV inputs can be differ, including different module types, numbers of connecting PV strings and orientation angels of PV module.

There are four types of DC connectors: DEVALAN, MC4, AMPHENDL H4 and QC4.10 series.

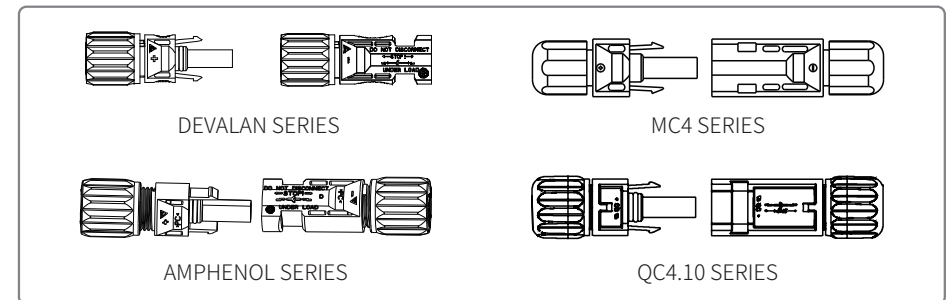

Note: The actual DC connector used is as shown in the accessory box.

DC cable specification:

Label	Description	Value
A	External diameter of wire stock	4~5mm
B	Cross-sectional area of conductor material	2.5~4mm ²
C	Length of bare wire	About 7mm

The installation method for DC connector.

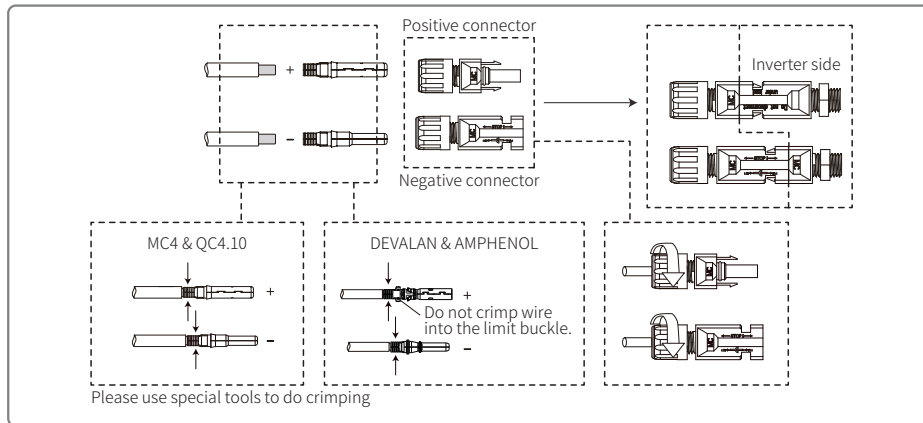

To better dustproof and waterproof the internal inverter, all DC connectors provided in the accessory bag should be connected to the inverter. If only some of the DC connectors are used, the DC connectors without connection should be blocked with a non-conductive insulator.

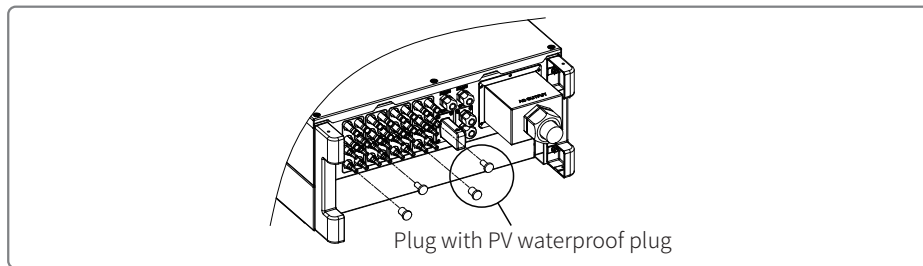

4.3.5 DC Switch

The DC switch is designed to be safely disconnected from the DC input if required.

The inverter works automatically when the input and output meet the requirements. Rotating the DC switch to the 'OFF' position will immediately cut off the flow of DC current.

Rotate the DC switch to the 'ON' position before starting the inverter.

4.4 Communication Connection

Inverter operation data can be transferred by USB, RS485 or WI-FI Module to a PC with monitoring software or to a data logger device (e.g Ezlogger Pro). USB is only used for service debugging; The RS485 is the standard communication choice for the inverter, and WI-FI module can be used optionally for communication.

4.4.1 USB Connection

USB cable must be connected according to the following steps, shown below:

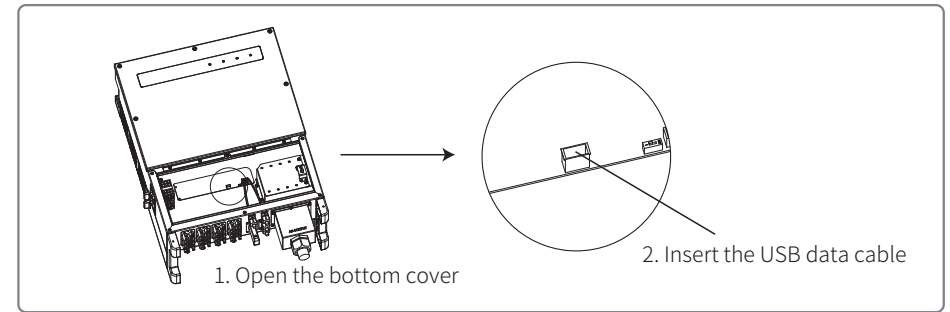

This function is only for local firmware upgrades and parameter calibrations.

4.4.2 RS485 Communication

This function only applies to the inverter with RS485 ports.

The RS485 port of the inverter is used to connect the EzLogger Pro, and the total length of connecting cable should not exceed 1000m.

Communication lines must be separated from other power lines to prevent interference to the communication. RS485 connections are shown as below.

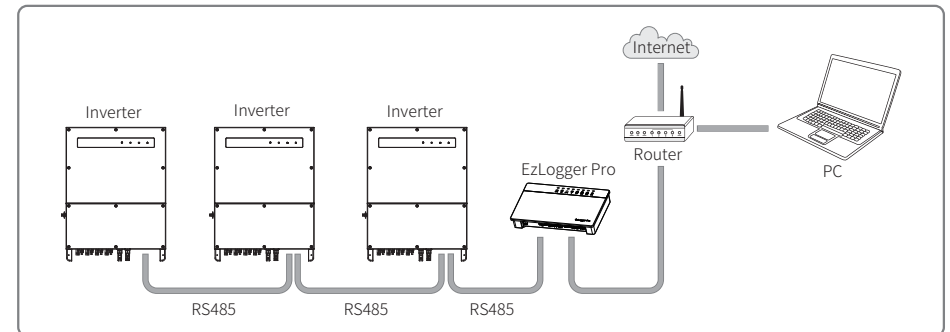

The connection steps of RS485 communication of MT series are as follows:

Step 1: Find the RS485 terminal and screw out the screw cap.

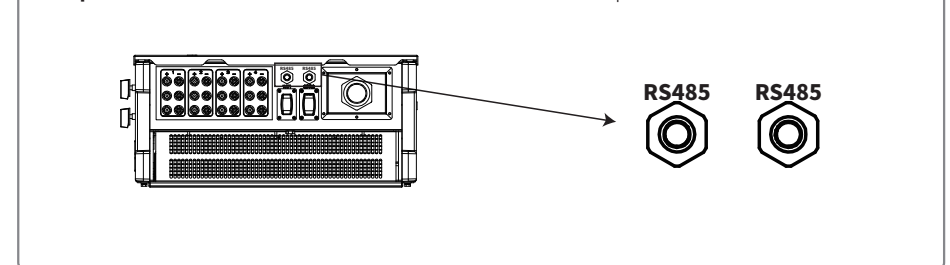

Step 2:

Put the cable through the plate, and connect RS485 cable on the 6-pin terminal.

Advise to use cable 16AWG-26AWG.

No.	Function
1	RS485+
2	RS485-
3	Reserved
4	Reserved
5	RS485+
6	RS485-

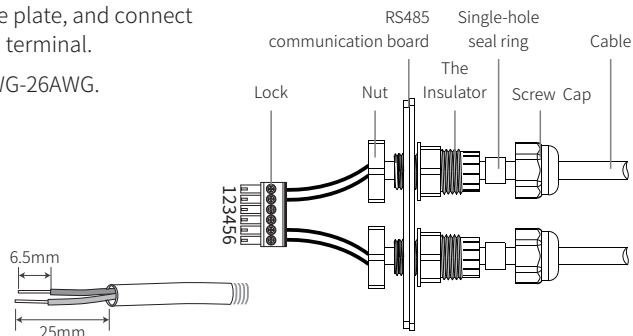

Step 3:

Connect the terminal to the right position onto the inverter.

Note: The terminal of different inverter model may be located in a different place.

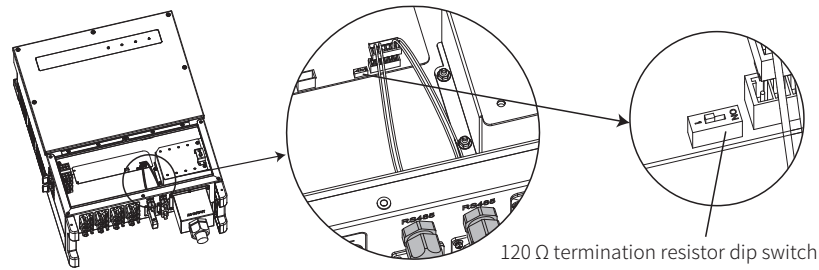

Caution

Cable requirements of RS485 communication: Shielded twisted-pair cable or shielded twisted-pair

Ethernet cable 120 Ω termination resistor is controlled by dip switch. 'ON' means connected, and 'OFF' means disconnected.

The terminal resistance dial switch is selected to 120 Ω.

- When A single inverter is in communication, rotate the terminal resistance dial switch to the 'ON' state (The default state is 'OFF') which is next to the RS485 communication port of inverter, so that the RS485 terminal is 120Ω. Then, ensure the shielding layer of communication line is single-point grounded.

If multiple inverters are in communication, connect all of them in a daisy chain through the

RS485 communication cable. For device at the end of the daisy chain, rotate the terminal resistance dial switch to the 'ON' state (The default state is 'OFF'). Then, ensure the shielding layer of communication line is single-point grounded.

4.4.3 Wi-Fi Communication

This function is only applicable for Wi-Fi model inverter. Please refer to 'Wi-Fi Configuration Instruction' to complete WiFi configuration.

After the configurations are completed, please register on the website: www.goodwe.com.

Please refer to Wi-Fi app for specific configuration.

The Wi-Fi module installation of MT series are shown as below.

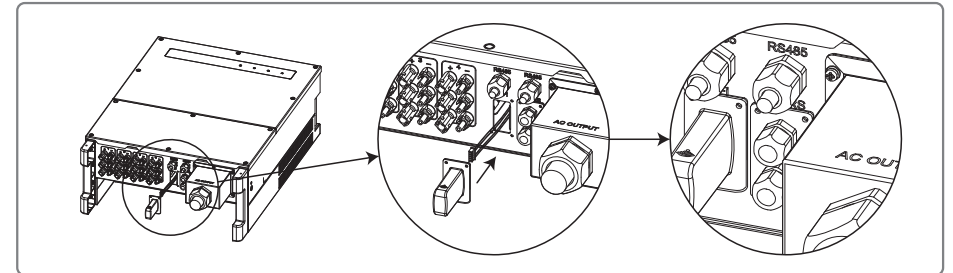

4.4.4 DRED (Demand response enabling device)

DRED function is achieved using the Ezlogger Pro. Please connect the Ezlogger Pro through the RS485 port. Please refer to the Ezlogger Pro manual for detailed DRED connections.

You can refer to EzLogger Pro SERIES USER MANUAL. Visit

https://en.goodwe.com/Public/Uploads/sersups/GW_EzLogger%20Pro_User%20Manual-EN.pdf to get the user manual.

4.4.5 Remote Shutdown

Step1:

Unscrew this plate from the inverter.

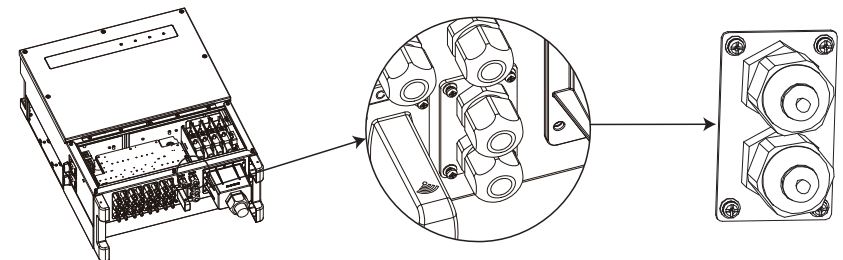

5 System Operation

5.1 LCD Panel and LED

As a human-computer interaction interface, the LCD display panel comprises LED indicators, buttons and a display on the front panel of the inverter.

The LED interface provides the working status of the inverter.

Buttons and LCD are used for configuration and viewing parameters.

LCD panel is included in GW30KLV-MT / GW35KLV-MT / GW50KN-MT / GW60KN-MT / GW50KBF-MT / GW70KHV-MT model type.



LED only panel is included in: GW50KN-MT / GW50KLV-MT / GW50KBF-MT / GW50KBF-MT-KR / GW60KBF-MT-KR / GW60KN-MT / GW60KBF-MT / GW70KHV-MT / GW75K-MT / GW80KHV-MT / GW80K-MT and GW80KBF-MT.



Green / green / green / red light respectively corresponds to: / / /

Indicator	Status	Explanation
		ON = Equipment Power-on
		OFF = Equipment Power-off
		ON = Inverter is feeding power
		OFF = Inverter is not feeding power
		Single slow flash = Self check before grid connects
		Single flash = Will connect / active
		ON = Wireless connected / active
		Blink 1 = Wireless system resetting
		Blink 2 = Wireless router problem
		Blink 4 = Wireless server problem
		Blink = RS485 Connected
		OFF = Wireless not active
		ON = Fault occurred
		OFF = No fault

Step2:

1. Plug out the 4-pin terminal and dismantle the resistor on it.
2. Plug the wire out; leave the 4-pin terminal for the next step.

The diagram shows the internal components of the inverter. A circular inset provides a magnified view of a 4-pin terminal with a resistor. An arrow points to a separate diagram showing the terminal with the resistor removed and the wire being unplugged. The text 'Unplug The wire' is written next to the terminal.

Step3:

Insert the gateway cable through the components as follows: screw cap, one-hole sealing ring, insulation body and sheet-metal parts.

No.	Function
1	24V
2	Shutoff_1
3	24V
4	Shutoff_2

The diagram shows a cable with four wires labeled 1, 2, 3, and 4. Dimensions are given: 6.5mm for the wire diameter and 25mm for the length of the insulation. The assembly process is shown with labels: Screw, Nut, The Insulator, and Screw Cap. The components are being inserted into the RS485 communication board, a single hole seal ring, and a cable.

Step4:

1. Connect the terminal to the right position of the inverter.
2. Fasten the waterproof plate to the inverter.

The diagram shows the inverter's internal components. A circular inset provides a magnified view of the terminal being connected to the right position of the inverter. The text 'Fasten the waterproof plate to the inverter.' is written next to the inset.

4.5 Precaution For Initial Startup

1. Make sure the AC circuit is connected and AC breaker is turned off.
2. Make sure the DC cable between inverter and PV string is connected, and the PV voltage is normal.
3. (Optional) Turn on the DC switch, and set safety according to the local regulation.
4. Turn on the AC breaker. Check the inverter work normal.

5.2 User Interface Introduction

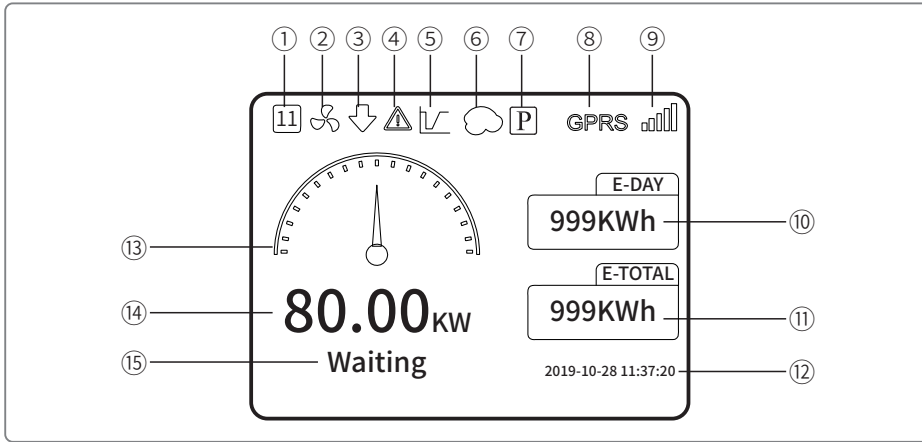

- ① Safety code: The number represents the safety serial number
- ② Fan icon: The fan icon indicates that the fan is on
- ③ Power Derating: The output power of the inverter is derating
- ④ Alarm icon: The alarm icon indicates that the system LVRT function is on
- ⑤ LVRT icon: The LVRT icon indicates that the system LVRT function is on
- ⑥ Shadow scan: The Shadow icon indicates that the Shadow scan function is on
- ⑦ PID icon: The PID icon indicates the existence of the PID module
- ⑧ Communication icon: Method of communication: GPRS, Wi-Fi or RS485
- ⑨ Communication information icon: GPRS and Wi-Fi show signal strength; RS485 shows the communication address.
- ⑩ E-Day icon: Daily generation
- ⑪ E-Total: Total generation
- ⑫ Time and date
- ⑬ Real-time power icon
- ⑭ Real-time power
- ⑮ System status information

5.2.1 Overview of Menu Architecture

The display menu has a total of three levels. Use the 'Up' 'Down' 'Enter' 'ESC' button to operate the menu. The enter button has two operating methods: long-press (greater than 3s) and short-press. In summary, there are 5 buttons total to operate the menu.

Press the 'Enter' / 'ESC' to enter / exit the each level menu, use the 'Up' / 'Down' to select the item and change the parameters, and long press the 'Enter' (greater than 3s) to set the parameters.

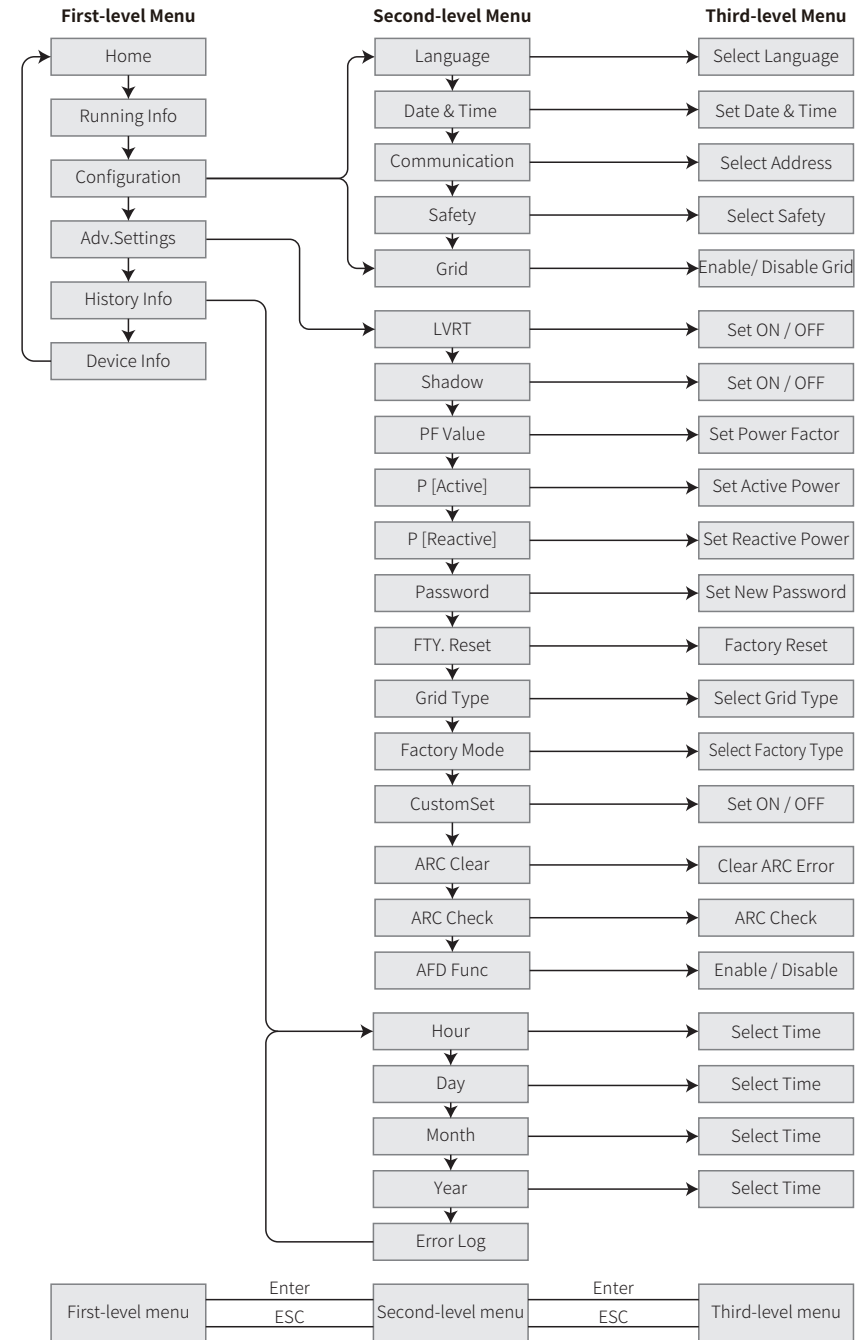

5.2.2 First-level Menu

Press 'up' / 'down' to select on the interface of First-level: History, Configuration, Adv.Settings etc. Pressing the Enter button will enter corresponding Second-level menu. Select the item through the 'up' / 'down' in Second-level menu. Press Enter button to enter the project setup menu in the Third-level menu, change the setting contents by pressing the 'up' / 'down', and press the 'Enter' to set the contents. If the country's safety setting is not selected (shows 'Configure Safety' on display at home page), press any button to enter country's safety setting page.

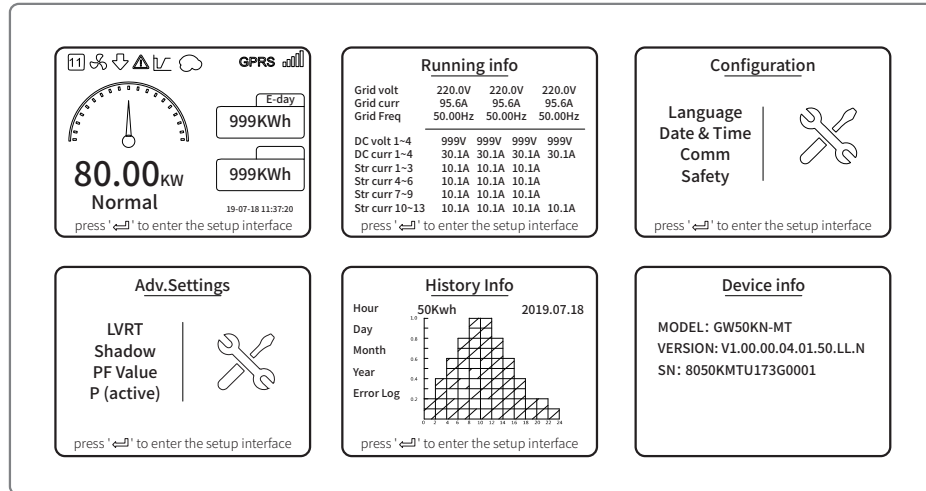

5.3 System Configuration

5.3.1 Basic Settings

Basic settings are mainly used to set the commonly used parameters, including language settings, time settings, communication settings and safety settings .

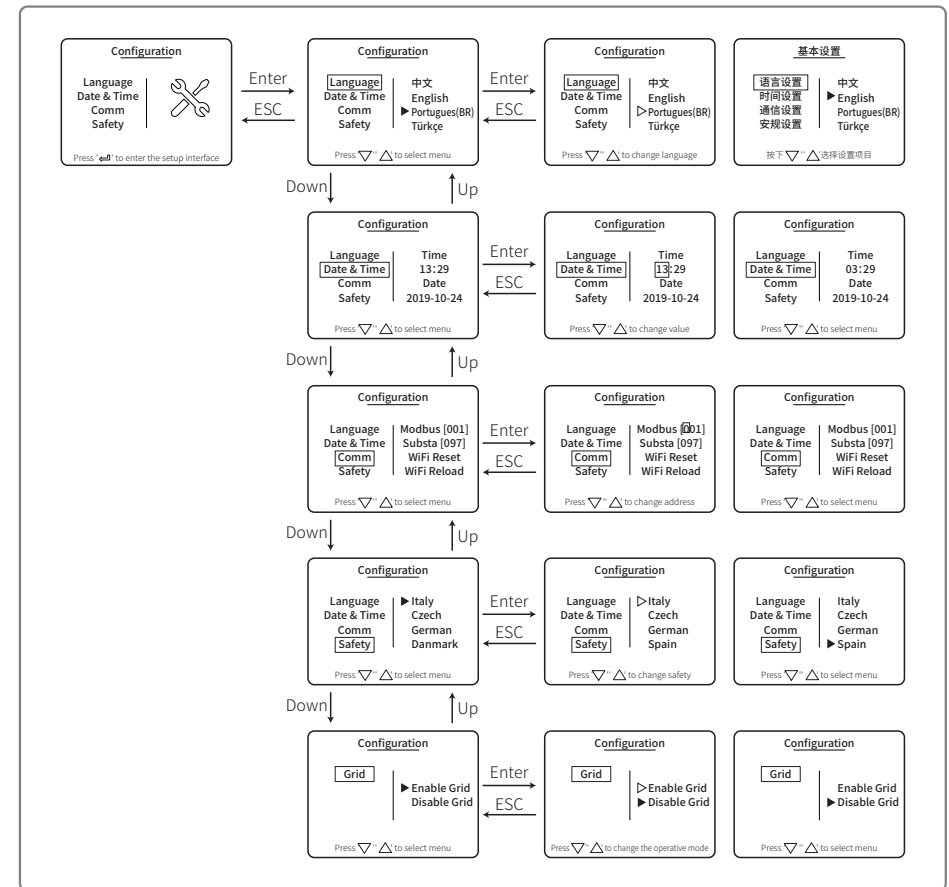

5.3.2 Advanced Settings

Advanced settings are mainly used to set the function parameters of the equipment to running modes. To prevent the device from running abnormally because of improper operation, all advanced-settings items requires a password. Therefore, enter a password so that you can set all the settings in the 'advanced setting' menu. In case the customer forgets the password, all devices have a unique super password and SN binding.

Advanced settings items include LVRT settings, Shadow settings, PF value settings, Active power settings, Reactive power settings and password modification settings.

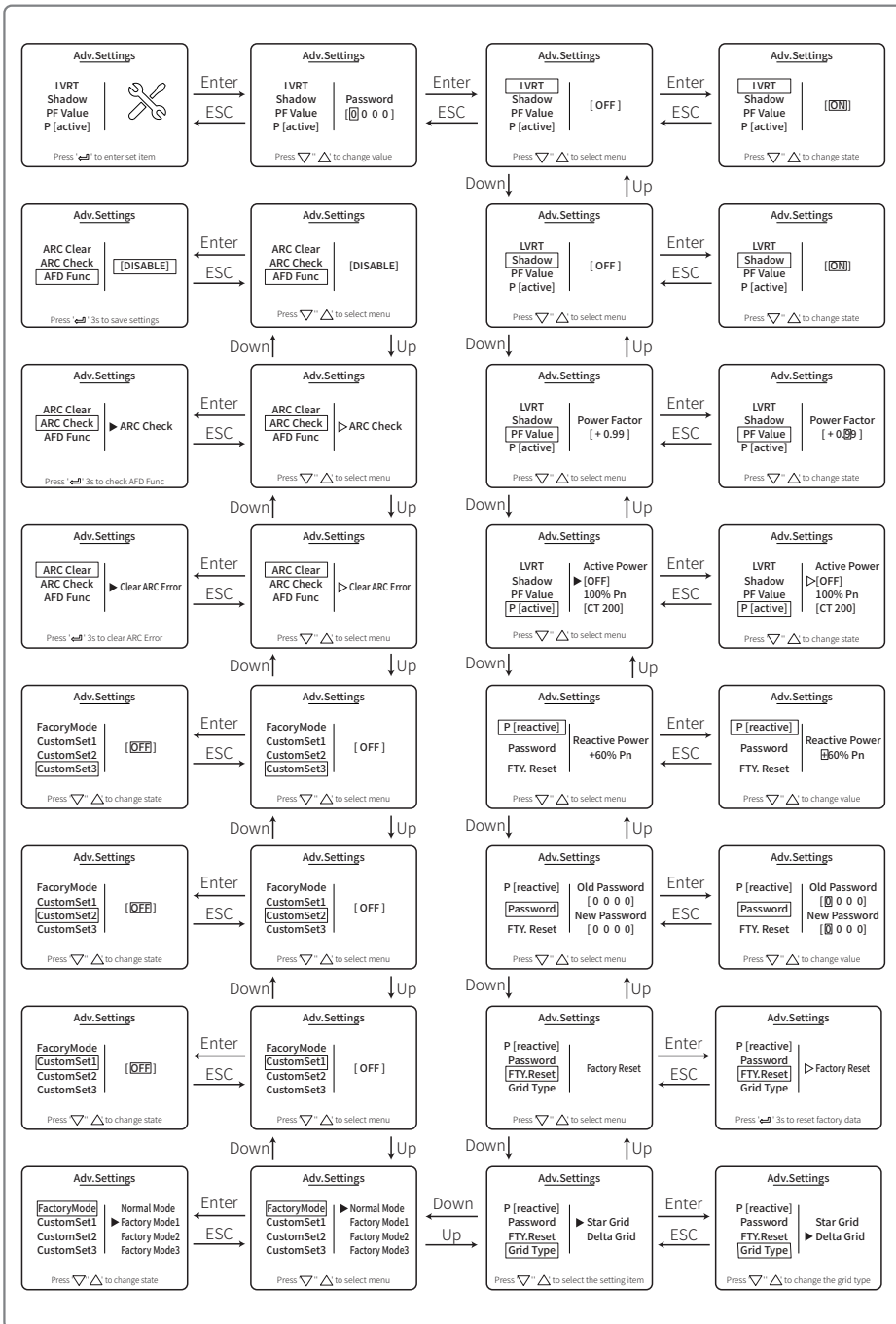

5.3.3 History Information

The history information mainly includes in the information about the generating capacity of the equipment, the fault record, the power generation information. The power generation information mainly includes in the amount of electricity generation, daily power generation, monthly power generation and annual power generation information.

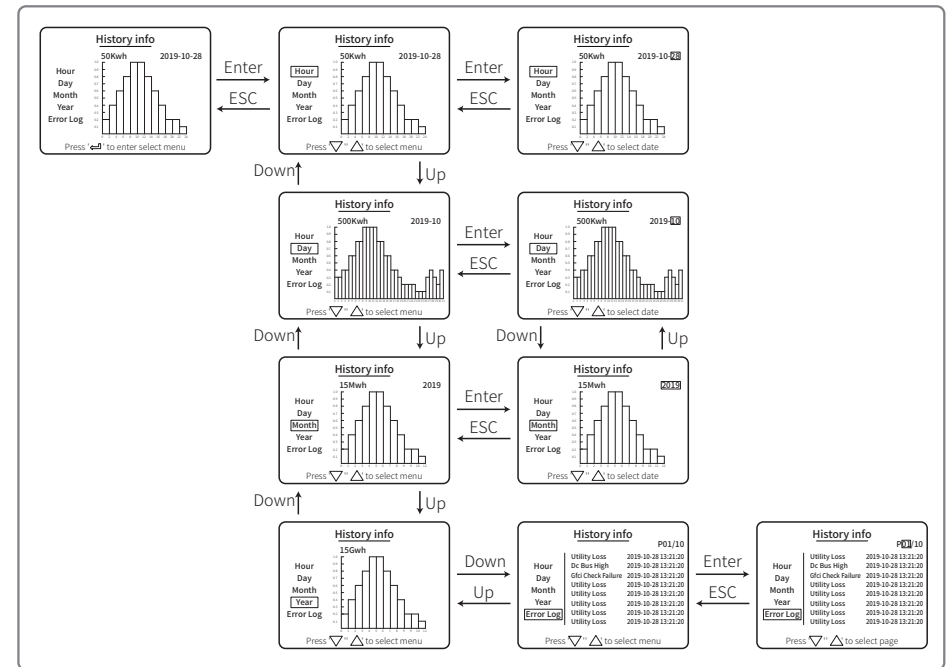

5.3.4 Operation of Display When Started Up

When the input voltage reaches the inverter's turn-on voltage, the LCD will indicate 'WAITING'. If the grid is accessible, 'Checking xxx Sec' (The time is decided by the grid connection standards from a different country) will appear after 5 s. As it is counting, the inverter is self-checking. When it shows '00Sec', you will hear the voice from the motion of the relay. The LCD will display 'Normal' afterwards. The instant power output will be shown at the left of the LCD.

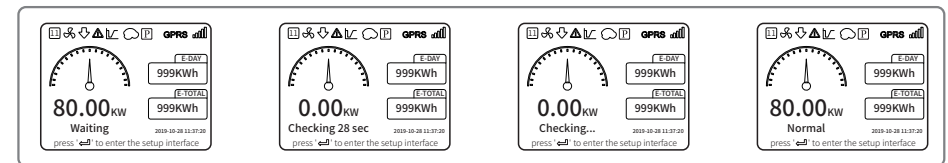

5.6 Monitoring via SEMS Portal

SEMS Portal is an monitoring platform used to manage organizations/users, add plants, and monitor plant status.

For more details, refer to the SEMS Portal User Manual. Scan the QR code or visit

https://en.goodwe.com/Ftp/EN/Downloads/User%20Manual/GW_SEMS%20Portal-User%20Manual-EN.pdf to get the user manual.



SEMS Portal App



SEMS Portal Web User Manual

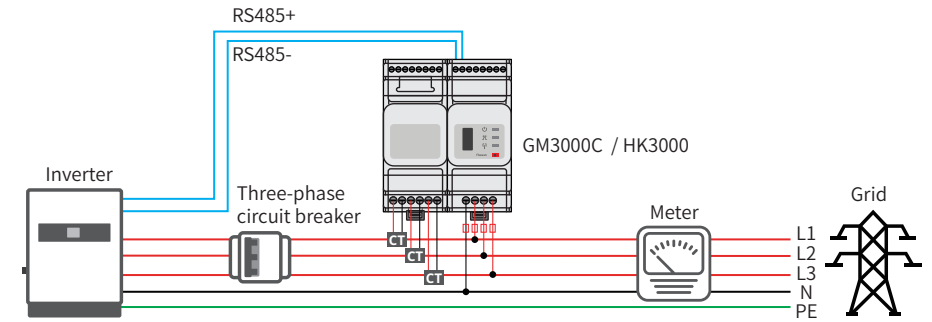

Power limit networking scenario (multi inverter)

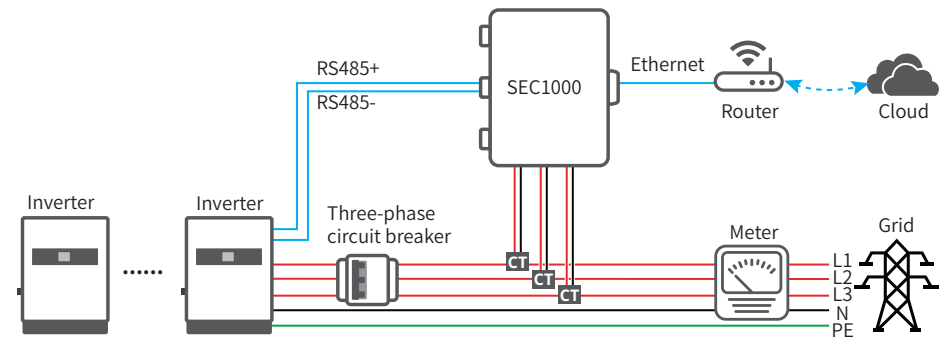

Set related parameters via SolarGo app to enable export power limit control or output power limit control.

5.7 Special Adjustable Setpoints

NOTE: For the Australian market, to comply with AS/NZS 4777.2:2020, please select from Australia Region A/B/C, please contact your local electricity grid operator on which Region to select. After the safety area setting is completed, some parameters in the inverter system will take effect according to the corresponding safety regulations, such as PU curve, QU curve, trip protection, etc. If you need to change the configuration parameters, please refer to the SolarGo APP user manual.

5.8 Power Limit Setting

Power limit networking scenario (single inverter)

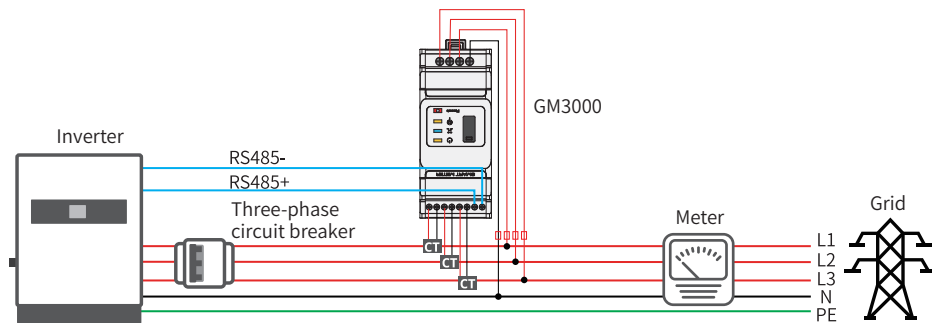

5.3.5 Menu Introduction

When PV panel is feeding power to the inverter, the screen shows the first interface of the first-level menu. The interface displays current state of the system. It shows 'Waiting' when in the initial state; it shows 'Normal' when in the power generation mode. If there is something wrong with the system, an error message will be shown. Please refer to '5.6 Error Message'.

- In the first-level menu, the displayed information can be switched via the 'Up' and 'Down' button operation. There are 6 interfaces in total, which are circulatory. The second-level menu can only be selected using the 'Enter' button from the seventh interface.
- In the 'History Info' menu, press 'Enter' and 'Down' to select 'Error Log', press 'Enter' to enter the historical error message interface. Press 'Up' and 'Down' to switch the display page and inquire the historical error message. Press 'ESC' to return to the upper menu.
- In the 'Configuration' menu, select 'Date & Time' to enter the setting interface, Press 'Up' and 'Down' to change the data, short-press 'Enter' to move cursor, long-press 'Enter' to save the settings.
- You must type in the password before entering the Advantage Setting. The inverter's default password is 1111. You can set the parameters and modify the password after this password verification is passed. If you forget your password, please contact after-sales for help.
- In 'Configuration' menu, select 'Language' and press 'Enter' to enter language setting interface, press 'Up' or 'Down' to change language, long-press 'Enter' to save the settings, press 'ESC' to return.
- In the 'History Info' menu, short-press 'Enter' to enter the second-level and third-level menu. In the third-level menu, press 'up' or 'down' to inquire the historical power generation data in Year Mode, Month Mode, Day Mode and Hour Mode. Press 'ESC' to return to upper menu.
- In 'Configuration' menu, choose 'Comm' and press 'Enter' to enter the Modbus address interface. Press 'Up' or 'Down' to set the address, long press 'Enter' to save the address.

⚠️ This function is used for special requirements, please don't set it arbitrarily.

- In the second-level menu, select 'LVRT' (if LVRT mode has not been turned on), it will show '[OFF]' on the right hand side of the LCD. Then press 'Up' or 'Down' to change the state to '[ON]'. Long press 'Enter' to save the setting. Then the screen will soon display '[ON]' after a while. This means that LVRT mode has been successfully turned on.

⚠️ This function is used for special requirements, please do not set it arbitrarily.

- In the second-level menu, select 'Shadow' (if shadow mode has not been turned on). It will show '[OFF]' on the right hand side of the LCD. Then press 'Up' or 'Down' to change the state to '[ON]'. Long press 'Enter' to save the setting, and the screen will display '[ON]' after a while, so that the Shadow mode has been successfully turned on.

⚠️ This function is used for special requirements, please do not set it arbitrarily.

- Select 'Safety' in the 'Configuration' menu, then press 'Enter', so that the set safety interface will be shown. Press 'Down' or 'Up' to choose the safety you need and then long press 'Enter'.

The chosen safety option will be set. If there is no exact proper country code, please choose '50Hz Grid Default' or '60Hz Grid Default' accordingly.

5.4 Wi-Fi Reset & Wi-Fi Reload

These functions are only available for Wi-Fi model inverters.

1. In the 'Configuration' menu, select 'Wi-Fi Reset' and press 'Enter' for 3 seconds to reset inverter Wi-Fi module. Wait for a while. The operation result will be shown on the display. The function can be applied when the inverter is unable to connect to router or monitor server.

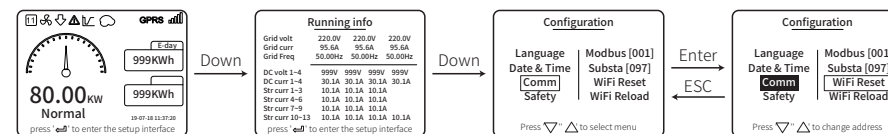

2. In the 'Configuration' menu, select 'Wi-Fi Reload' at level 3. Press 'Enter' for 3 seconds. The initial settings of the Wi-Fi module will be reloaded. Wait for a while. The operation result will be shown on the display. The function can be applied when inverter is unable to connect to Wi-Fi module. After Wi-Fi module is restored to its initial settings, the Wi-Fi module needs to be reset again.

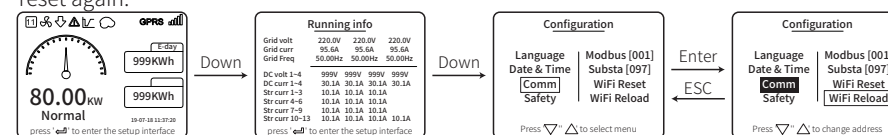

5.5 Setting Inverter Parameters via App

SolarGo is an application used to communicate with the inverter via Bluetooth module, WiFi module, or GPRS module. Commonly used functions:

1. Check the operating data, software version, alarms of the inverter, etc.
2. Set grid parameters and communication parameters of the inverter.
3. Maintain the equipment.

For more details, refer to the SolarGo APP User Manual. Scan the QR code or visit

https://en.goodwe.com/Ftp/EN/Downloads/User%20Manual/GW_SolarGo_User%20Manual-EN.pdf to get the user manual.



SolarGo App



SolarGo App User Manual

5.9 Error Message

The error message in below diagram will be displayed on the LCD if faults occur.

Error code	Error message	Description
01	SPI Failure	Internal communication failure
02	EEPROM R/W Failure	Memory chip failure
03	Fac Failure	Grid Frequency exceed the inverter limit
07, 25	Relay Check Failure	Relay self-checking failure
12	LCD Communication Failure	Communication error occurs between LCD DSP and the Master DSP
13	DC Injection High	The DC component of AC current exceed inverter's limit
14	Isolation Failure	Insulation Resistance between the ground and the panel is too low
15	Vac Failure	Grid voltage exceeds the inverter limit
16	External Fan Failure	External Failure
17	PV Over Voltage	PV Array voltage exceeds the inverter limit
19	Over Temperature	Over temperature on the case
20	IFAN Fault	Internal FAN Fault
21	DC BUS HIGH	BUS voltage is too high
22	Ground I Failure	Residual current protection
23	Utility Loss	Grid disconnection/fault
30	REF 1.5V Failure	1.5V reference voltage exceeds the limit
31, 24	AC HCT Failure	AC current sensor failure
32, 26	GFCI Failure	Leakage current detection circuit Failure
Others	Device Failure	Internal Device Failure

6 Troubleshooting

If the Inverter is unable to work properly, please refer to the following instructions before contacting your local service centre. If any problems arise, the red (FAULT) LED indicator on the front panel will light up and the LCD screen will display relevant information. Please refer to the following table for a list of error message and associated solutions.

Type of fault	Troubleshooting	
System Failure	Isolation Failure	<ol style="list-style-type: none"> 1. Check the impedance between Ground and PV (+) & PV (-). The impedance value must be greater than 100 kΩ. Ensure the inverter is earthed. 2. Contact local service office for help if the problem persists.
	Ground I Failure	<ol style="list-style-type: none"> 1. The ground current is too high. 2. Unplug the inputs from the PV generator and check the peripheral AC system. 3. When the problem is cleared, reconnect the PV panel and check the Inverter status. 4. Contact local service office for help if the problem persists.
	Vac Failure	<ol style="list-style-type: none"> 1. The PV Inverter will automatically restart within 5 minutes if the grid returns to normal. 2. Ensure grid voltage conforms with the specification. 3. Ensure neutral (N) wire and PE wire are connected well. 4. Contact local service office for help if the problem persists.
	Fac Failure	<ol style="list-style-type: none"> 1. Grid is not connected. 2. Check grid connection cables. 3. Check availability of grid.
	Utility Loss	<ol style="list-style-type: none"> 1. Not connect to the grid. 2. Check if the power grid is connected to cable. 3. Check the availability of power grid.
	PV Over Voltage	<ol style="list-style-type: none"> 1. Check if the PV open circuit voltage is higher or too close to the maximum input voltage or not. 2. If the problem persists when PV voltage is less than the maximum input voltage, contact local service office for help.
	Over Temperature	<ol style="list-style-type: none"> 1. The internal temperature is higher than normal value specified. 2. Reduce ambient temperature. 3. Move the inverter to a cool place. 4. If the problem still exists, contact local service office for help.

Type of fault		Troubleshooting
Inverter Failure	Relay-Check Failure	<ol style="list-style-type: none"> Turn off DC switch of the inverter. Wait until the inverter's LCD light is off. Turn on the DC switch and ensure it is connected. If the problem persists, contact local service office for help.
	DCI Injection High	
	EEPROM R/W Failure	
	SCI Failure	
	SPI Failure	
	DC BUS High	
	BUS Unbalance	
	GFCI Failure	
	Ifan Fault	
	Efan Fault	
Afan Fault		
Others	No display	<ol style="list-style-type: none"> Turn off the DC switch, take off the DC connector and measure the voltage of the PV array. Plug in the DC connector, and turn on DC switch. If PV array voltage is lower than 250V, please check the configuration of inverter module. If voltage is higher than 250V, please contact the local office.
	Wi-Fi module fail to connect to network	<ol style="list-style-type: none"> If the Wi-Fi module fails to connect to the network after choosing the right router hotspot and entering the right passwords, it is possible that there are special characters in the hotspot's password that are not supported by module. Please modify the password to comprise only Arabic numerals or uppercase / lowercase letters. If the problem persists, contact the local service office for help.

Note:

When sunlight is insufficient, the PV Inverter may continuously start up and shut down automatically because of insufficient power generation by the PV panel.

Earth Fault Alarm

The inverter complies with IEC62109-2 13.9. When an earth fault occurs, a buzzer in the EzLogger Pro will ring for 1 min, and an LED will be lit for 1 min. The alarm will ring again every half hour unless the fault is resolved.

You can refer to EzLogger Pro SERIES USER MANUAL. Visit

https://en.goodwe.com/Public/Uploads/sersups/GW_EzLogger%20Pro_User%20Manual-EN.pdf to get the user manual.

7 Technical Parameters & Block Diagram

7.1 Technical Parameters

Technical Data	GW30KLV-MT	GW35KLV-MT	GW50KLV-MT
DC Input Data			
Max. PV Power (W)	54000	63000	90000
Max. DC Input Voltage (V)	800	800	800
MPPT Range (V)	200~650	200~650	200~650
Starting Voltage (V)	200	200	200
Min. Feed-in Voltage(V)	210	210	210
Nominal DC Input Voltage (V)	370	370	370
Max. Input Current (A)	33/33/22/22	33/33/33/33	44/44/44/44
Max. Short Current (A)	41.5/41.5/27.5/27.5	41.5/41.5/41.5/41.5	55/55/55/55
No. of MPP Trackers	4	4	4
No. of Input Strings per Tracker	3/3/2/2	3/3/3/3	4/4/4/4
AC Output Data			
Nominal Output Power (W)	30000	36000	50000
Max. Output Power (W)	208VAC	28800	34500
	220VAC	30000	36000
	240VAC	33000	39900
Max. Output Apparent Power (VA)	33000	39900	55000
Nominal Output Voltage (V)	150~300	150~300	150~300
Nominal Output Frequency (Hz)	50/60	50/60	50/60
Max. Output Current (A)	80	96	133
Output Power Factor	~1 (Adjustable from 0.8 leading to 0.8 lagging)		
Output THDi (@Nominal Output)	<3%		
Efficiency			
Max. Efficiency	98.7%	98.8%	98.7%
European Efficiency	98.3%	98.5%	98.3%
Protection			
PV String Current Monitoring	Integrated		
Anti-islanding Protection	Integrated		
Input Reverse Polarity Protection	Integrated		
Insulation monitoring	Integrated		
DC fuse	Integrated		
Anti-PID Function for Module	Optional		
DC SPD Protection	Integrated (Type II)		
AC SPD Protection	Integrated (Type II)		
Residual Current Monitoring Unit	Integrated		
AC Over Current Protection	Integrated		
AC Short Protection	Integrated		
AC Over Voltage Protection	Integrated		
General Data			
Ambient Temperature Range (°C)	-30~60(60 °C for outdoor unconditioned with solar effects.)		
Relative Humidity	0~100%		
Operating Altitude (m)	≤4000		
Cooling	Fan Cooling		
Display	LCD or WiFi+APP	LCD or WiFi+APP	LED, WiFi+APP
Communication	RS485 or WiFi	RS485 or WiFi	RS485&WiFi, PLC(Optional)
Weight (kg)	59	64	70
Dimension (Width * Height * Depth mm)	586*788*264	586*788*264	586*788*267
Protection Degree	IP65		
Night Self Consumption (W)	<1		
Topology	Transformerless (Non-isolated)		
Certifications & Standards			
Grid Regulation	Visit homepage to achieve information.		
Safety Regulation			
EMC Regulation			

Technical Data	GW50KN-MT	GW60KN-MT	GW80K-MT
Input			
Max. Input Power (W)	65000	80000	120000
Max. Input Voltage (V)	1100	1100	1100
MPPT Operating Voltage Range (V)	200~1000	200~1000	200~1000
MPPT Voltage Range at Nominal Power (V)	520~850	520~850	465~850
Start-up Voltage (V)	200	200	200
Nominal Input Voltage (V)	620	620	620
Max. Input Current per MPPT (A)	33/33/22/22	33/33/33/33	44/44/44/44
Max. Short Circuit Current per MPPT (A)	41.5/41.5/27.5/27.5	41.5/41.5/41.5/41.5	55/55/55/55
Max. Backfeed Current to The Array (A)	0	0	0
Number of MPP Trackers	4	4	4
Number of Strings per MPPT	3/3/2/2	3/3/3/3	4(Standard), 3(Optional,Support bifacial module)
Output			
Nominal Output Power (W)	50000	60000	80000
Nominal Output Apparent Power (VA)	50000	60000	80000
Max. AC Active Power (W)	55000; 57500@415V	66000; 69000@415V	88000
Max. AC Apparent Power (VA)	55000; 57500@415V	66000; 69000@415V	88000
Nominal Output Voltage (V)	400, 3L/N/PE or 3L/PE		
Nominal AC Grid Frequency (Hz)	50/60		
Max. Output Current (A)	80	96	133.0
Max. Output Fault Current (Peak and Duration) (A/ms)	210@1ms	210@1ms	300@1ms
Inrush Current (Peak and Duration) (A/us)	160@5μs	160@5μs	177@5μs
Maximum Output Overcurrent Protection (A)	200	200	250
Nominal Output Current (A)	72.2	86.6	115.5
Power Factor	~1 (adjustable from 0.8 lagging to 0.8 leading)		
Max. Total Harmonic Distortion	<3%		
Efficiency			
Max. Efficiency	98.7%	98.8%	98.8%
European Efficiency	98.3%	98.5%	98.3%
Protection			
PV String Current Monitoring	Integrated		
PV Insulation Resistance Detection	Integrated		
Residual Current Monitoring	Integrated		
PV Reverse Polarity Protection	Integrated		
Anti-islanding Protection	Integrated		
AC Overcurrent Protection	Integrated		
AC Short Circuit Protection	Integrated		
AC Overvoltage Protection	Integrated		
DC Switch	Optional		
DC Surge Protection	Type II		
AC Surge Protection	Type II		
AFCI	Optional		
PID Recovery	Optional		
DC Fuse Current Rating (A)	15	15	20(3 strings); 15(4 strings)
General Data			
Operating Temperature Range (°C)	-30~60(60 °C for outdoor unconditioned with solar effects.)		
Relative Humidity	0~100%		
Max. Operating Altitude (m)	4000		
Cooling Method	Smart Fan Cooling		
Display	LED, LCD (Optional), WiFi+APP	LED, LCD (Optional), WiFi+APP	LED, WiFi+APP
Communication	RS485, WiFi or PLC(Optional)		
Weight (kg)	59.0	64.0	70.0
Dimension W×H×D (mm)	586 x 788 x 264	586 x 788 x 264	586 x 788 x 267
Noise Emission (dB)	<60	<65	<65

Technical Data	GW50KN-MT	GW60KN-MT	GW80K-MT
General Data			
Topology	Non-isolated		
Self-consumption at Night (W)	<1		
Ingress Protection Rating	IP65		
Anti-corrosion Class	C4		
Environmental Category	4K4H		
Pollution Degree	III		
Overvoltage Category	DC II / AC III		
Protective Class	I		
Active Anti-islanding Method	AFDPF + AQDPF		
The Decisive Voltage Class (DVC)	PV:C ; AC:C; com:A		
Country of Manufacture	China		

[1] For Belgium Max. Output Power (W): GW50KN-MT is 50000; GW60KN-MT is 60000; GW80K-MT is 80000;

[2] For Belgium Max. Output Apparent Power (VA): GW50KN-MT is 50000; GW60KN-MT is 60000; GW80K-MT is 80000;

Technical Data	GW60KBF-MT	GW75KBF-MT	GW50KBF-MT
DC Input Data			
Max. PV Power (W)	80000	97500	65000
Max. DC Input Voltage (V)	1100	1100	1100
MPPT Range (V)	200-1000	200-1000	200-1000
Starting Voltage (V)	200	200	200
Min. Feed-in Voltage(V)	210	210	210
Nominal DC Input Voltage (V)	620	750	620
Max. Input Current (A)	44/44/44/44	44/44/44/44	30/30/30/30
Max. Short Current (A)	55/55/55/55	55/55/55/55	37.5/37.5/37.5/37.5
No. of MPP Trackers	4	4	4
No. of Input Strings per Tracker	3/3/3/3	3/3/3/3	2/2/2/2
AC Output Data			
Nominal Output Power (W)	60000	75000	50000
Max. Output Power (W) [1]	66000;69000@415Vac	82500*	55000;57500@415Vac
Max. Output Apparent Power (VA) [2]	66000;69000@415Vac	82500*	55000;57500@415Vac
Nominal Output Voltage (V)	400, default 3L+N+PE , 3L+PE optional in settings	500, 3L/PE	400, default 3L+N+PE , 3L+PE optional in settings
Nominal Output Frequency (Hz)	50/60	50/60	50/60
Max. Output Current (A)	96	95.3	80
Output Power Factor	~1 (Adjustable from 0.8 leading to 0.8 lagging)		
Output THDi (@Nominal Output)	<3%		
Efficiency			
Max. Efficiency	98.8%	99.0%	98.8%
European Efficiency	98.3%	98.4%	98.3%
Protection			
PV String Current Monitoring	Integrated		
Anti-islanding Protection	Integrated		
Input Reverse Polarity Protection	Integrated		
Insulation monitoring	Integrated		
DC fuse	Integrated		
Anti-PID Function for Module	Optional		
DC SPD Protection	Type II		
AC SPD Protection	Type II		
Residual Current Monitoring Unit	Integrated		
AC Over Current Protection	Integrated		
AC Short Protection	Integrated		
AC Over Voltage Protection	Integrated		
General Data			
Ambient Temperature Range (°C)	-30~60(60 °C for outdoor unconditioned with solar effects.)		
Relative Humidity	0~100%		
Operating Altitude (m)	≤4000		
Cooling	Fan Cooling		
Display	LED or WiFi+APP		
Communication	RS485 or WiFi or PLC		
Weight (kg)	65	65	60
Dimension (Width * Height * Depth mm)	586*788*267	586*788*267	586*788*264
Protection Degree	IP65		
Night Self Consumption (W)	<1		
Topology	Transformerless (Non-isolated)		
Certifications & Standards			
Grid Regulation	Visit homepage to achieve information.		
Safety Regulation			
EMC Regulation			

[1] For Belgium Max. Output Power (W): GW60KBF-MT is 60000; GW75KBF-MT is 75000; GW50KBF-MT is 50000;

[2] For Belgium Max. Output Apparent Power (VA): GW60KBF-MT is 60000; GW75KBF-MT is 75000; GW50KBF-MT is 50000;

Technical Data	GW70KHV-MT	GW80KHV-MT
DC Input Data		
Max. PV Power (W)	91000	120000
Max. DC Input Voltage (V)	1100	1100
MPPT Range (V)	200-1000	200-1000
Starting Voltage (V)	200	200
Min. Feed-in Voltage(V)	210	210
Nominal DC Input Voltage (V)	750	800
Max. Input Current (A)	33/33/33/33	44/44/44/44
Max. Short Current (A)	41.5/41.5/41.5/41.5	55/55/55/55
No. of MPP Trackers	4	4
No. of Input Strings per Tracker	3/3/3/3	3/3/3/3
AC Output Data		
Nominal Output Power (W)	70000	80000
Max. Output Power (W) [1]	77000*	88000*
Max. Output Apparent Power (VA) [2]	77000*	88000*
Nominal Output Voltage (V)	500, 3L/PE	500, 3L/PE
Nominal Output Frequency (Hz)	50/60	50/60
Max. Output Current (A)	89	94.1
Output Power Factor	~1 (Adjustable from 0.8 leading to 0.8 lagging)	
Output THDi (@Nominal Output)	<3%	
Efficiency		
Max. Efficiency	99.0%	99.0%
European Efficiency	98.4%	98.4%
Protection		
PV String Current Monitoring	Integrated	
Anti-islanding Protection	Integrated	
Input Reverse Polarity Protection	Integrated	
Insulation monitoring	Integrated	
DC fuse	Integrated	
Anti-PID Function for Module	Optional	
DC SPD Protection	Integrated (Type II)	
AC SPD Protection	Integrated (Type II)	
Residual Current Monitoring Unit	Integrated	
AC Over Current Protection	Integrated	
AC Short Protection	Integrated	
AC Over Voltage Protection	Integrated	
General Data		
Ambient Temperature Range (°C)	-30~60(60 °C for outdoor unconditioned with solar effects.)	
Relative Humidity	0~100%	
Operating Altitude (m)	≤4000	
Cooling	Fan Cooling	
Display	LCD or WiFi+APP	LED, WiFi+APP
Communication	RS485 or WiFi or PLC	
Weight (kg)	60	65
Dimension (Width * Height * Depth mm)	586*788*264	586*788*267
Protection Degree	IP65	
Night Self Consumption (W)	<1	
Topology	Transformerless (Non-isolated)	
Certifications & Standards		
Grid Regulation	Visit homepage to achieve information.	
Safety Regulation		
EMC Regulation		

[1] For Belgium Max. Output Power (W): GW70KHV-MT is 70000; GW80KHV-MT is 80000;

[2] For Belgium Max. Output Apparent Power (VA): GW70KHV-MT is 70000; GW80KHV-MT is 80000;

Technical Data	GW75K-MT	GW80K-MT
DC Input Data		
Max. PV Power (W)	112500	120000
Max. DC Input Voltage (V)	1100	1100
MPPT Range (V)	200~1000	200~1000
Starting Voltage (V)	200	200
Min. Feed-in Voltage (V)	210	210
Nominal DC Input Voltage (V)	600	620
Max. Input Current (A)	44/44/44/44	44/44/44/44
Max. Short Current (A)	55/55/55/55	55/55/55/55
No. of MPP Trackers	4	4
No. of Input Strings per Tracker	4/4/4/4 (Standard) 3/3/3/3 (Optional, Support bifacial module)	4/4/4/4 (Standard) 3/3/3/3 (Optional, Support bifacial module)
AC Output Data		
Nominal Output Power (W)	75000	80000
Max. Output Power (W) [1]	75000	88000*
Max. Output Apparent Power (VA) [2]	75000	88000*
Nominal Output Voltage (V)	400, default 3L+N+PE, 3L+PE optional in settings	400, default 3L+N+PE, 3L+PE optional in settings
Nominal Output Frequency (Hz)	50/60	50/60
Max. Output Current (A)	133	133
Output Power Factor	~1 (Adjustable from 0.8 leading to 0.8 lagging)	
Output THDi (@Nominal Output)	<3%	
Efficiency		
Max. Efficiency	98.8%	
European Efficiency	98.3%	
Protection		
PV String Current Monitoring	Integrated	
Anti-islanding Protection	Integrated	
Input Reverse Polarity Protection	Integrated	
Insulation monitoring	Integrated	
DC fuse	Integrated	
Anti-PID Function for Module	Optional	
DC SPD Protection	Integrated (Type II)	
AC SPD Protection	Integrated (Type II)	
Residual Current Monitoring Unit	Integrated	
Humidity Monitoring	Integrated	
AC Over Current Protection	Integrated	
AC Short Protection	Integrated	
AC Over Voltage Protection	Integrated	
General Data		
Ambient Temperature Range (°C)	-30~60(60 °C for outdoor unconditioned with solar effects.)	
Relative Humidity	0~100%	
Operating Altitude (m)	≤4000	
Cooling	Fan Cooling	
Display	LED, WiFi+APP	
Communication	RS485 & Wi-Fi, PLC(Optional)	
Weight (kg)	70	
Dimension (Width * Height *Depth mm)	586*788*267	
Protection Degree	IP65	
Night Self Consumption (W)	<1	
Topology	Transformerless (Non-isolated)	
Certifications & Standards		
Grid Regulation	Visit homepage to achieve information.	
Safety Regulation		
EMC Regulation		

[1] For Belgium Max. Output Power (W): GW80K-MT is 80000;

[2] For Belgium Max. Output Apparent Power (VA): GW80K-MT is 80000;

Technical Data	GW50KBF-MT-KR	GW60KBF-MT-KR
Input		
Max. Input Power (W)	65000	80000
Max. Input Voltage (V)	1100	1100
MPPT Operating Voltage Range (V)	200~1000	200~1000
Start-up Voltage (V)	200	200
Backfeed Current (A)	0	0
Nominal Input Voltage (V)	620	620
Max. Input Current per MPPT (A)	30	30
Max. Short Circuit Current per MPPT (A)	37.5	37.5
Number of MPPT	4	4
Number of Strings per MPPT	2	2
Output		
Nominal Output Power (W)	50000	60000
Max. AC Active Power (W) [1]	55000	66000
Max. AC Apparent Power (VA)[2]	55000	66000
Nominal Output Voltage (V)	400, 3L/N/PE or 3L/PE	400, 3L/N/PE or 3L/PE
Nominal AC Grid Frequency (Hz)	50/60	50/60
Max. Output Current (A)	80	96
Output Power Factor	~1 (Adjustable from 0.8 leading to 0.8 lagging)	
Max. Total Harmonic Distortion	<3%	
Max. Output Fault Current (peak and duration) (A)	180(duration 5us)	180(duration 5us)
Max. Output Overcurrent Protection (A)	180	180
Efficiency		
Max. Efficiency	98.8%	98.8%
European Efficiency	98.3%	98.5%
Protection		
PV String Current Monitoring	Integrated	
Anti-islanding Protection	Integrated	
DC Insulation Resistance Detection	Integrated	
DC fuse	Integrated	
Anti-PID Function for Module	Optional	
DC Surge Arrester	Integrated (Type II)	
AC Surge Arrester	Integrated (Type II)	
Residual Current Monitoring Unit	Integrated	
AC Overcurrent Protection	Integrated	
AC Short Circuit Protection	Integrated	
AC Overvoltage Protection	Integrated	
General Data		
Operating Temperature Range (°C)	-30~60	
Relative Humidity	0~100%	
Max. Operating Altitude (m)	4000	
Cooling Method	Smart Fan Cooling	
Display	LCD or WiFi+APP	
Communication	RS485 or WiFi or PLC	
Weight (kg)	59kg	64kg
Dimension (Width * Height * Depth mm)	586*788*264	
Ingress Protection Rating	IP65	
Night Self Consumption (W)	<1	
Topology	Transformerless	
Certifications & Standards		
Grid Regulation	Visit homepage to achieve information.	
Safety Regulation		
EMC Regulation		

Note:

Overvoltage Category Definition

Category I: applies to equipment connected to a circuit where measures have been taken to reduce transient overvoltage to a low level.

Category II: applies to equipment not permanently connected to the installation. For example, appliances, portable tools and other plug-connected equipment;

Category III: applies to fixed downstream equipment, including the main distribution board. This includes switchgear and other equipment in an industrial installation;

Category IV: applies to equipment permanently connected at the origin of an installation (upstream of the main distribution board). For example, electricity meters, primary overcurrent protection equipment and other equipment connected directly to outdoor open lines.

Moisture Location Category Definition

Moisture parameters	Level		
	3K3	4K2	4K4H
Temperature Range	0~+40°C	-33~+40°C	-20~+55°C
Humidity Range	5%~85%	15%~100%	4%~100%

Environment Category Definition

Outdoor: the ambient air temperature is -20-50°C. Relative humidity range is 4-100%, applied to PD3.

Indoor unconditioned: the ambient air temperature is -20-50°C. Relative humidity range is 5- 95%, applied to PD3.

Indoor conditioned: the ambient air temperature is 0-40°C. Relative humidity range is 5- 85%, applied to PD2.

Pollution Degree Definition

Pollution degree 1: No pollution or only dry, non-conductive pollution occurs. The pollution has no influence.

Pollution degree 2: Normally only non-conductive pollution occurs. However, a temporary conductivity occasionally caused by condensation must be expected.

Pollution degree 3: Conductive pollution occurs, or dry, non-conductive pollution becomes conductive because of condensation, which is expected.

Pollution degree 4: Persistent conductive pollution occurs. This includes the pollution cause by conductive dust, rain and snow.

7.2 Block Diagram

GW30KLV-MT / GW50KN-MT main circuit.

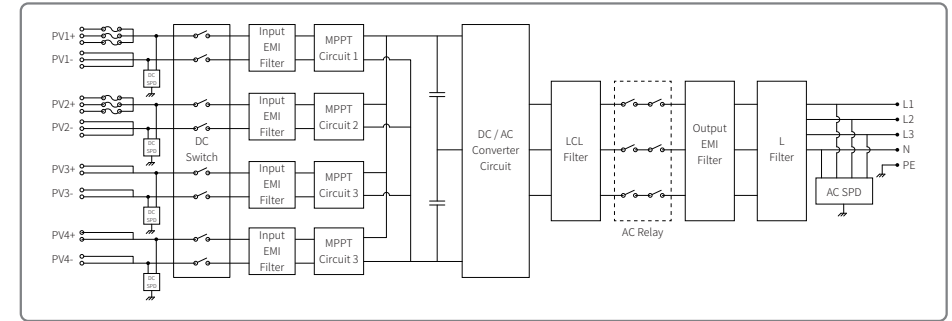

GW50KBF-MT / GW50KBF-MT-KR main circuit.

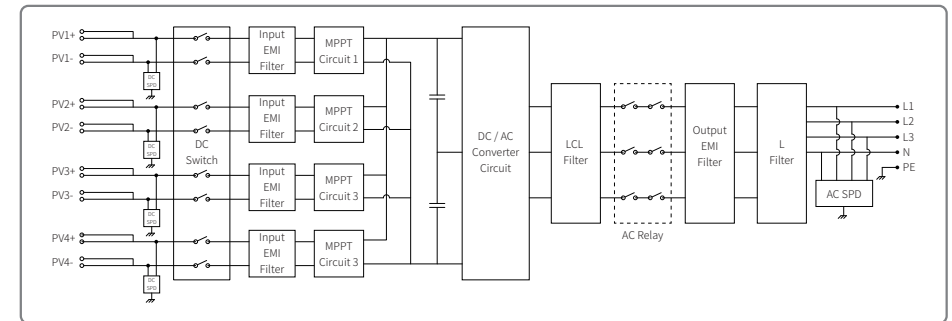

GW35KLV-MT / GW60KN-MT / GW60KBF-MT-KR / GW60KBF-MT main circuit.

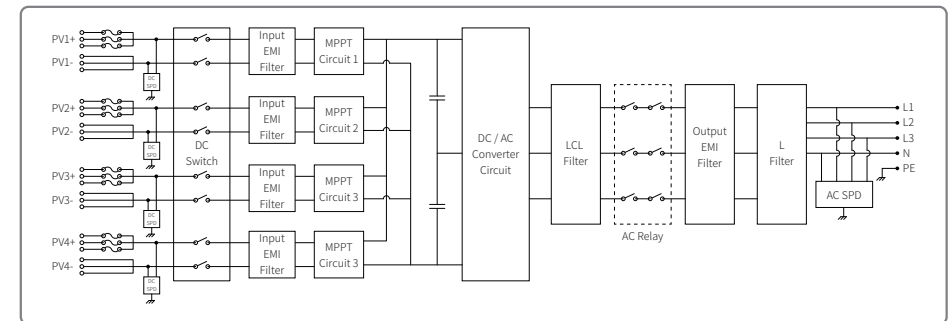

GW70KHV-MT / GW80KBF-MT main circuit.

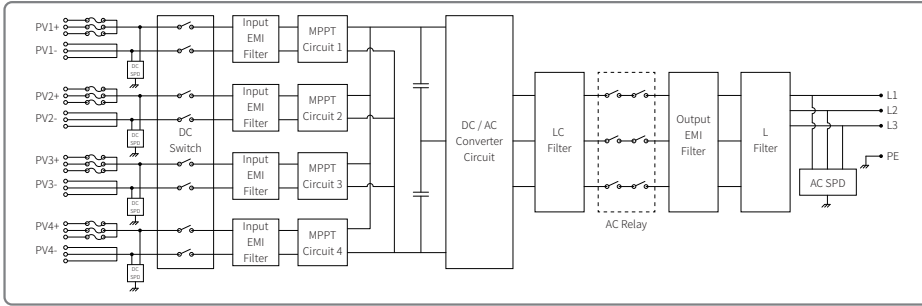

GW80KHV-MT main circuit.

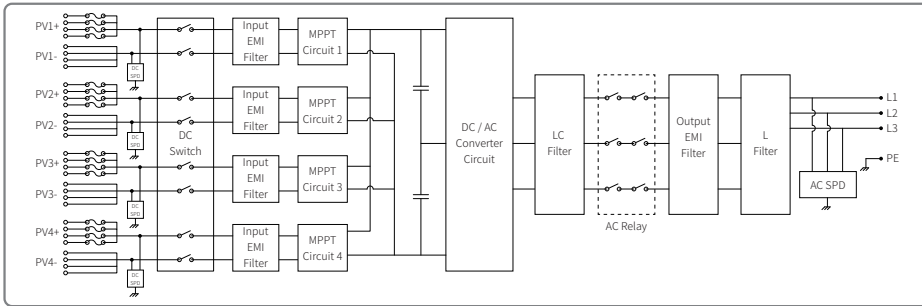

GW50KLV-MT / GW75KW-MT / GW80K-MT PV3 main circuit.

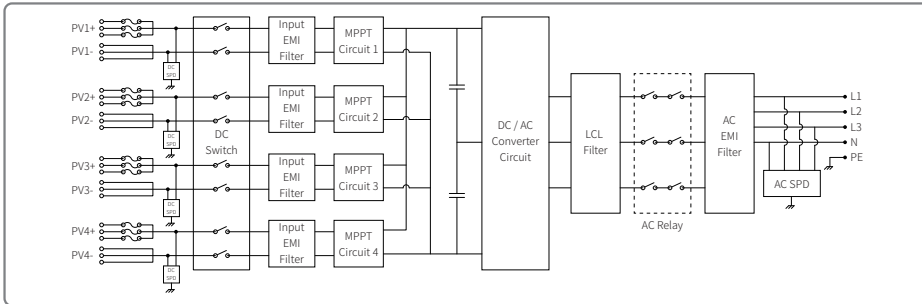

GW50KLV-MT / GW75KW-MT / GW80K-MT PV4 main circuit.

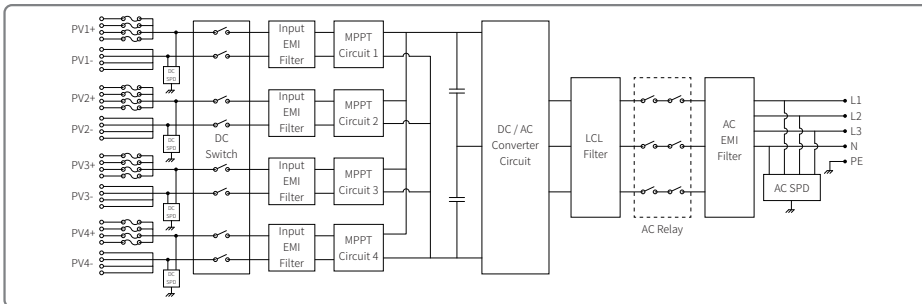

When GW50KN-MT without DC switch, the circuit diagram is as following.

For Australia and New Zealand.

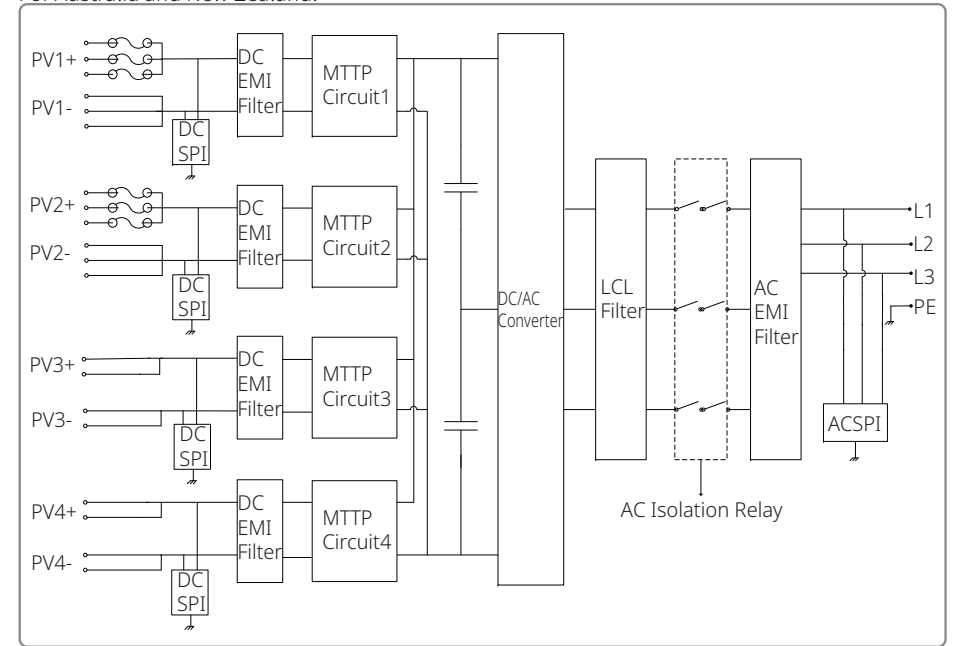

When GW60KN-MT without DC switch, the circuit diagram is as following.

For Australia and New Zealand.

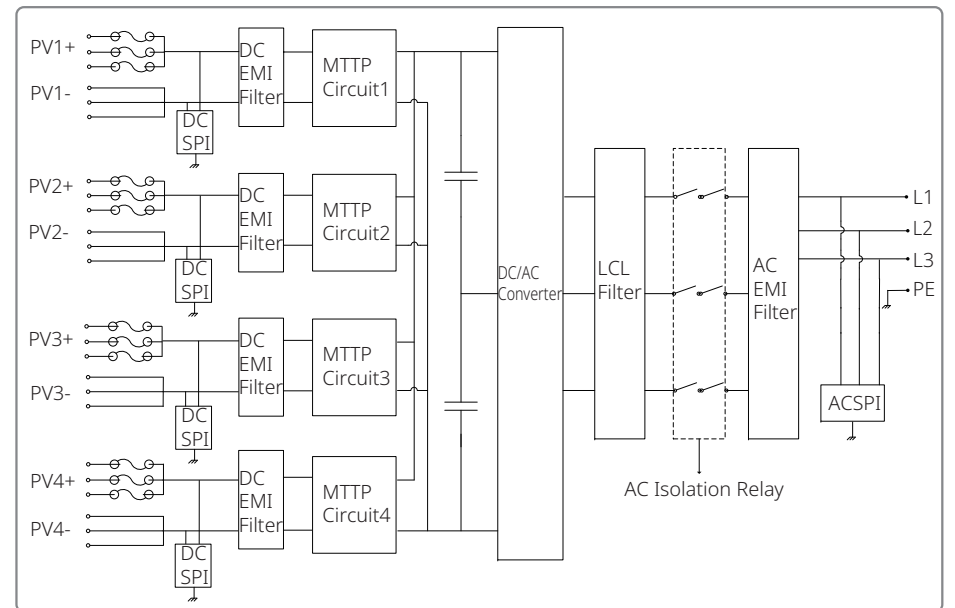

When GW80K-MT is equipped with 3 MPPTs but without DC switch, the circuit diagram is as following.
For Australia and New Zealand.

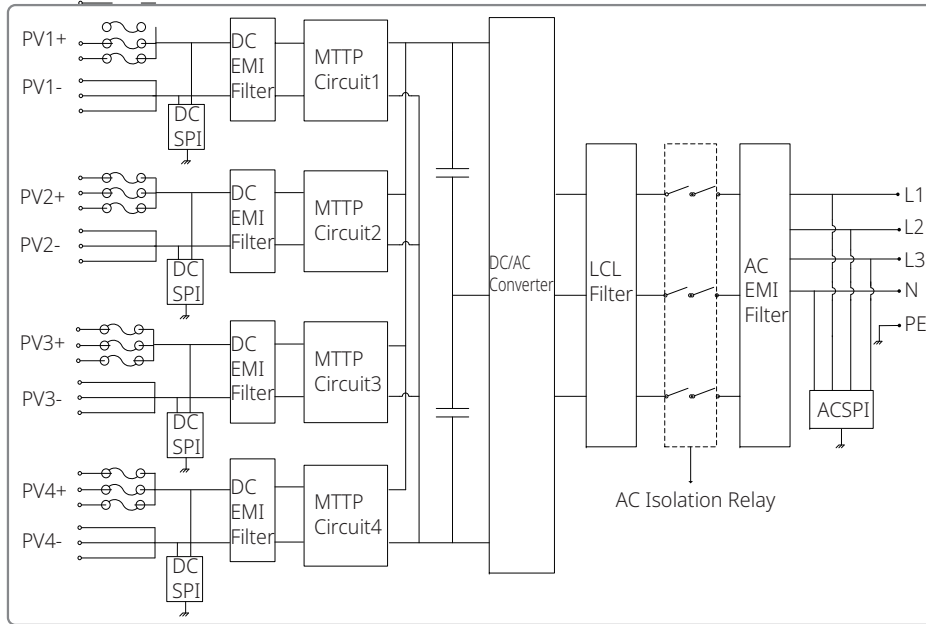

When GW80K-MT is equipped with 4 MPPTs but without DC switch, the circuit diagram is as following.
For Australia and New Zealand.

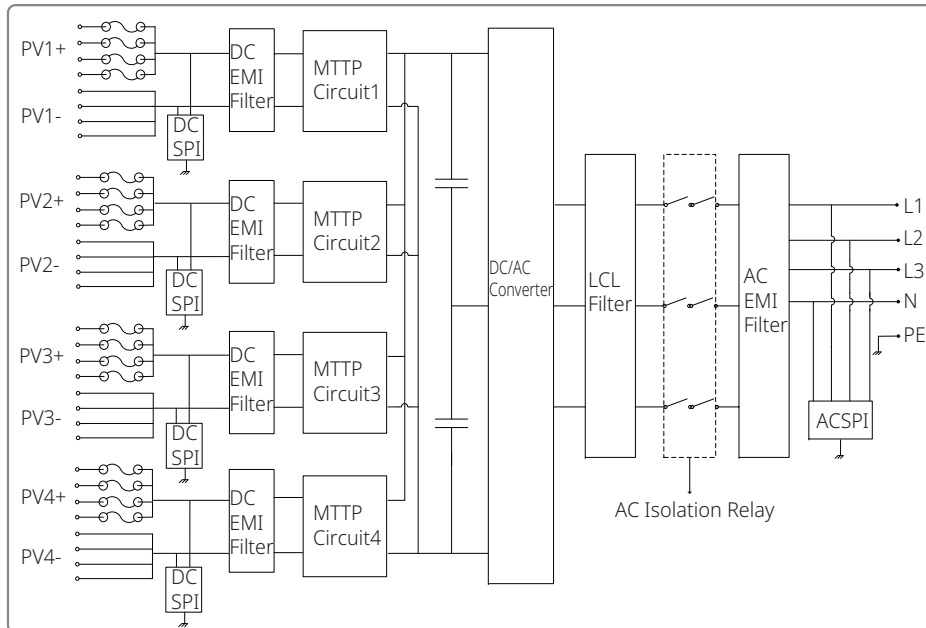

8 Maintenance

Regular maintenance ensures a long operating life and optimal efficiency of the entire PV plant.

Caution: Before maintenance, please first disconnect the AC breaker. Then disconnect the DC breaker. Wait 5 min until the residual voltage has been released.

8.1 Clearing The FAN

The MT series inverter is equipped with three fans on its left side. The fan intakes and handle covers should be cleaned yearly using a vacuum cleaner. For more thorough cleaning, completely remove the fans.

1. Disconnect the AC breaker first. Then, disconnect the DC breaker.
2. Wait 5 min until the residual voltage has been released, and the fans are no longer running.
3. Disassemble the fans (Refer to the below figure).
 - Loosen the five screws using a crosshead screwdriver. Then, slowly remove the fans out of the cabinet about 50mm.
 - Open the lockers of the three fan connectors and remove them from housing. Then uninstall the fans.
4. Clean the ventilation grid and the fans with a soft brush, or compressed air.
5. Reinstall the fans into the cabinet.

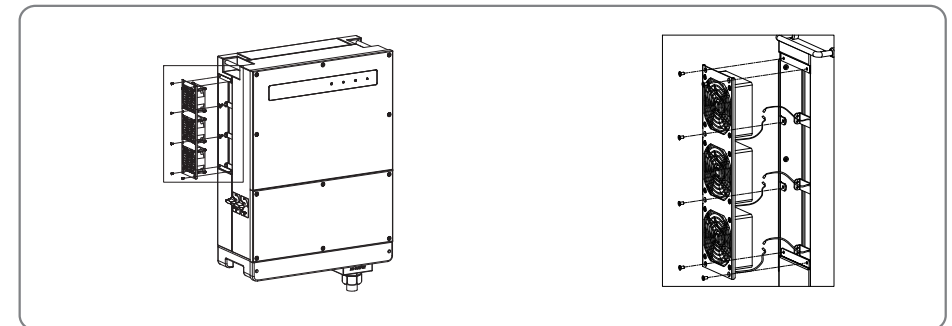

8.2 (Optional) Checking the DC switch

DC switch does not require any maintenance

Although not mandatory, maintenance below is still recommended:

- Check the DC switch regularly.
 - Activate the DC switch 10 times in a row once per year.
- Operating the switch will clean the switch and will extend its life .

8.3 Turn On / Off the Inverter

Boot order:

1. Turn on the breaker on the AC side.
2. (Optional) Turn on the DC switch.
3. Turn on the breaker on the DC side.

Note: If there is no switch, only perform steps 1 and 3 (please skip step 2).

Shutdown order:

1. Turn off the breaker on the AC side.
2. (Optional) Turn off the DC switch.
3. Turn off the breaker on the DC side.

Note: If there is no switch, only perform steps 1 and 3 (please skip step 2).

8.4 Checking the Electrical Connection

1. Check if the AC or DC wire is loose.
2. Check to ensure the earth wire is reliably grounded.
3. Check if the waterproof covers of the RS485 and USB port are fastened.

Note: Maintenance cycle is once every half year.

8.5 Fuse Replacement

If the inverter fuses are broken, replace them quickly. The steps are as follows:

1. Disconnect the circuit breaker on the AC side.
2. Rotate the DC switch to the 'OFF' position.
3. Disconnect the front-end circuit breaker of the PV input terminal or pull out the PV input terminal.
4. Wait at least 10 min.
5. Open the junction box's cover on the bottom of inverter.
6. Confirm that the fuses are broken.
7. Remove the broken fuses vertically as shown in the right figure. Do not remove fuses by prying or via similar methods.
8. Install the same model fuses from the same company to the corresponding fuse holders.
9. Install the junction-box cover on the inverter.

