



APPLICATION GUIDE FOR FRONIUS TAURO DATA COMMUNICATION

Correct configuration of data communication for the Fronius Tauro

© Fronius International GmbH
Version V1.0 May/2021 Peter Schmidhuber, Jasmin Gross
Solar Energy

Fronius reserves all rights, in particular rights of reproduction, distribution and translation. No part of this document may be reproduced, in any form whatsoever, or stored, processed, duplicated or disseminated with the aid of electronic systems, without the written consent of Fronius. You are hereby reminded that the information published in this document, despite the greatest care being exercised in its preparation, is subject to change and that neither the author nor Fronius can accept any legal liability. Gender-specific wording refers equally to the male and female form

TABLE OF CONTENT

1	Introduction	4
2	Difference to SnapINverter series	5
3	Independent datcom cabling	5
4	Positioning of LAN switches	6
4.1	Example 1: All inverters in one direction	6
4.2	Example 2: Inverters positioned irregularly	7
4.3	Example 3: Precombined variant.....	8
5	LAN switch types and setup.....	9
5.1	Standard Ethernet switch.....	9
5.2	PoE switch	9
5.3	Outdoor switch without PoE.....	11
5.3.1	Supplied by 12 V output.....	11
5.3.2	Supplied by AC area.....	11
5.3.3	Supplied from AC area (incl. power adaptor)	12
5.4	Outdoor PoE switch	12
5.5	Built-in switch inside the Tauro	13
5.6	Real life example – Tauro pre-series in Austria.....	14

1 INTRODUCTION

This guide will provide assistance on the correct data communication cabling for Fronius Tauro devices. A stable data connection forms the basis for efficient monitoring and sustainable operation of the entire PV system.

2 DIFFERENCE TO SNAPINVERTER SERIES

With the earlier Fronius SnapInverter generation, data communication was carried out via a so-called Solar.Net ring. The LAN communication was established from inverter to inverter (up to 10 inverters) and resulted in lower star cabling costs. In the event of a data communication error on one device, all other devices in the same ring could also lose data communication.

3 INDEPENDENT DATCOM CABLING

Fronius Tauro devices are no longer connected in a Solar.Net ring for data communication cabling. The cabling is installed independently and individually in a **star network**. This results in more reliable communication due to a more robust cabling layout.

Star LAN layout for reliable data communication:

- / Easy to plan
- / Robust in case of failure
- / Easy and fast troubleshooting
- / 100 m distance allowed (LAN standard)
- / Switches as signal amplifiers used
- / PoE switch / outdoor switches

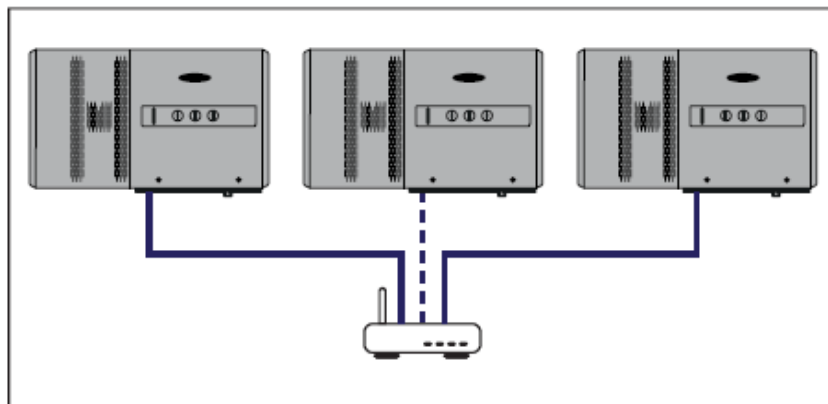

Picture 1: Individual LAN connection of Fronius Tauro

If more than 100 m of single cable length is necessary, a **LAN switch** has to be used to amplify the signal quality.

The following example situations are intended to give an impression of the simple use of LAN switches to ensure efficient data communication.

If a plant controller is needed, it can be easily integrated into the inverter communication network. Plant controllers are usually installed on the communication board. Current and voltage are measured on the main switchboard, depending on local regulations.

4 POSITIONING OF LAN SWITCHES

4.1 Example 1: All inverters in one direction

This example shows a decentralised system design, where all inverters (direct variant) are positioned in a row. The inverter at the farthest end of the field is 120 m away from the main switchboard/transformer. If more than 100 m of single cable length is necessary, a LAN switch has to be used to amplify the signal quality.

For an optimal result we suggest the following data communication setup:

Every inverter is connected independently to the main communication board via a LAN cable. LAN switch 1 is located on the main communication board next to the transformer. The nearest two inverters are connected to LAN switch 1. To connect further inverters, a second LAN switch is directly connected to LAN switch 1. For the most efficient cabling layout, all other Tauro devices in the field are connected to LAN switch 2.

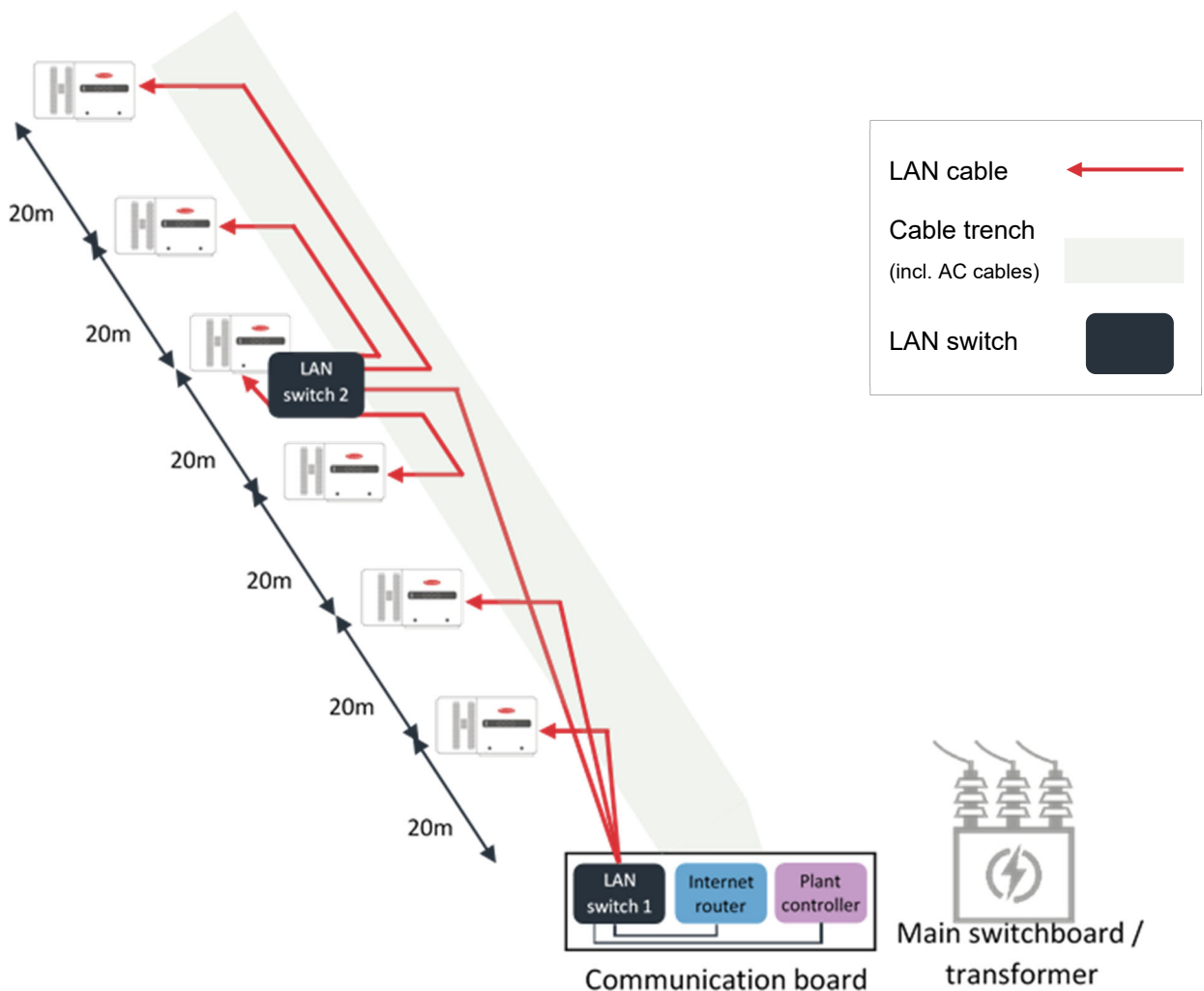

Picture 2: LAN switch connection Tauro D version, example 1

4.2 Example 2: Inverters positioned irregularly

This example shows a more complex system design, where all inverters (direct variant) are positioned irregularly around the field. If more than 100 m of single cable length is necessary, a LAN switch has to be used to amplify the signal quality.

For an optimal result we suggest the following data communication setup:

Every inverter is connected independently to the main communication board via a LAN cable. LAN switch 1 is located on the main communication board next to the transformer. The nearest inverters are connected to LAN switch 1. A second LAN switch is directly connected to switch 1, where again the closest inverters are connected. The devices at the end of the field are connected via a third LAN switch. LAN switch 3 is connected to LAN switch 2.

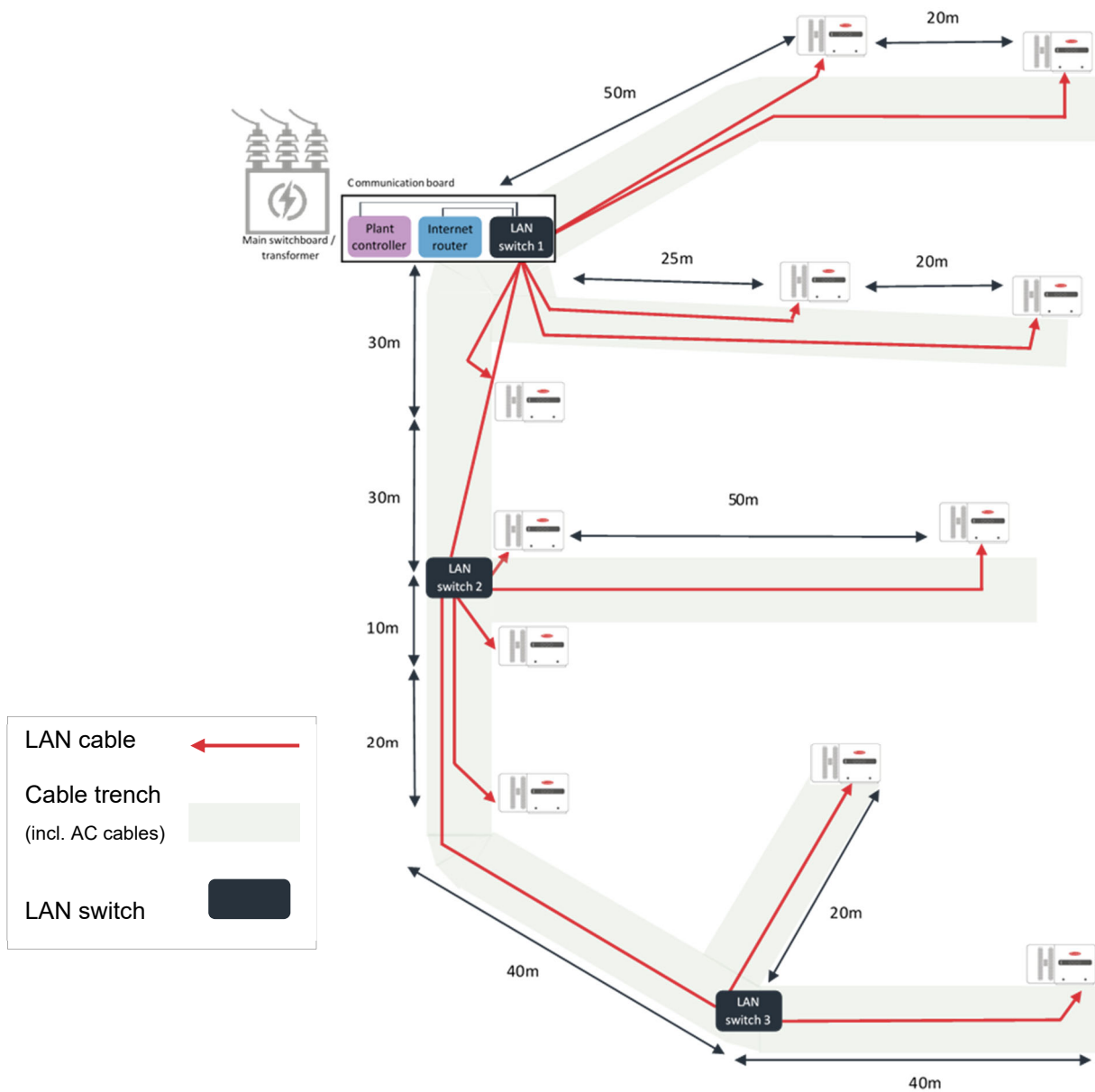

Picture 3: LAN switch connection Tauro D version, example 2

4.3 Example 3: Precombined variant

The following example shows the central system design with the Tauro P variant. The inverters are arranged centrally next to the transformer. The strings are collected with DC combiner boxes and then connected to the inverters. The LAN cabling is also installed in a star network.

For an optimal result we suggest the following data communication setup:

Every inverter is connected independently to the main communication board via a LAN cable. The main LAN switch is located on the main communication board next to the transformer. Since all inverters are situated very close to the transformer station, no more LAN switches are required.

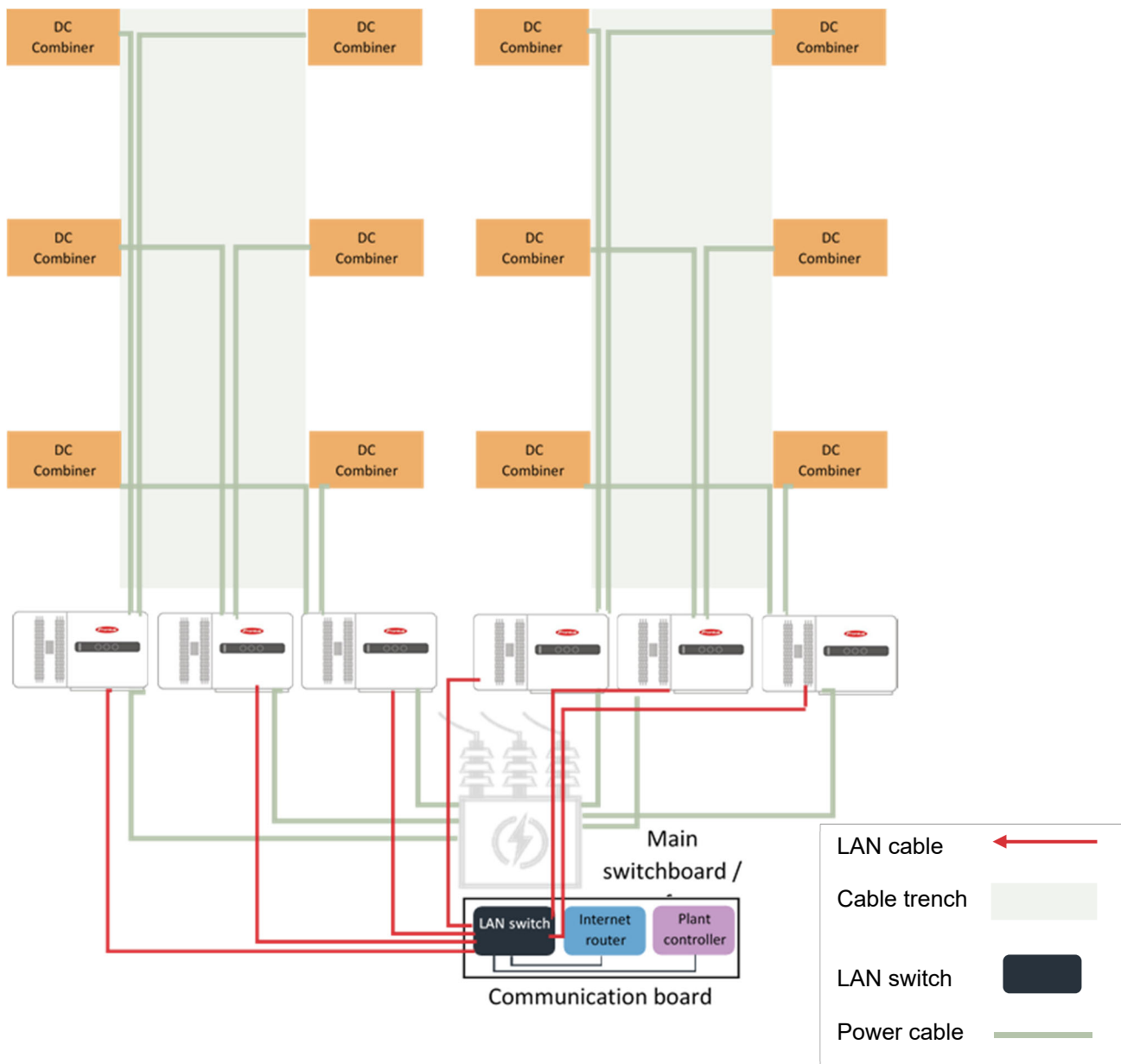

Picture 4: LAN connection within a central system design

5 LAN SWITCH TYPES AND SETUP

The following chapters deal with various LAN switch types and details about setup and cabling.

5.1 Standard Ethernet switch

Data communication and cabling layout is very easy to design when using standard Ethernet switches.

The following is required to implement a standard Ethernet switch:

- / Box with power supply and IP protection
- / Standard Ethernet switch

Cabeling

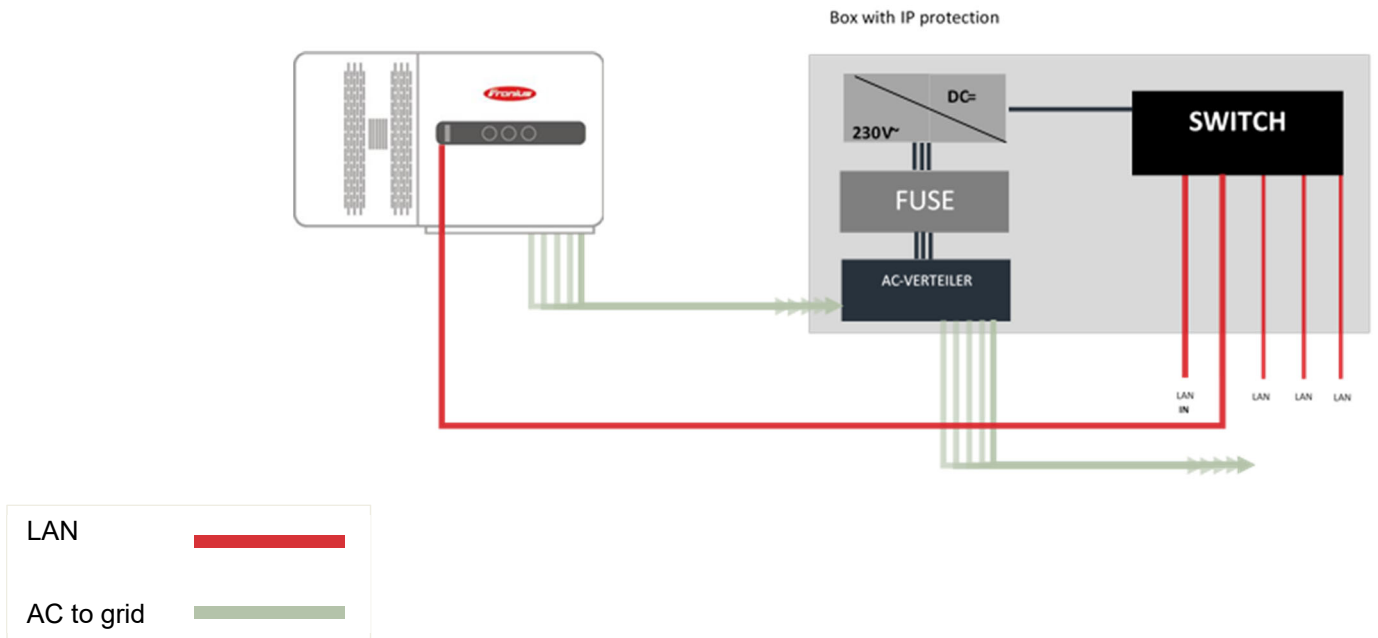

Picture 5: Connection to standard Ethernet switch

Inside the box, an AC connection with the proper fusing is realized. The Tauro is located at one side of the AC connection, with the grid connection at the other. The fusing must be chosen in accordance with local regulations. The power supply for the switch is usually supplied with the switch. Otherwise a suitable power supply (normally 12 V or 24 V) must also be installed.

5.2 PoE switch

Power over Ethernet (PoE) is another method for powering a LAN switch and is very popular.

The following is required to implement a standard PoE Ethernet switch:

.....

- / Box with IP protection
- / Standard PoE Ethernet switch

If there are multiple PoE switches within a single system, there are also two different types of switches that have to be used:

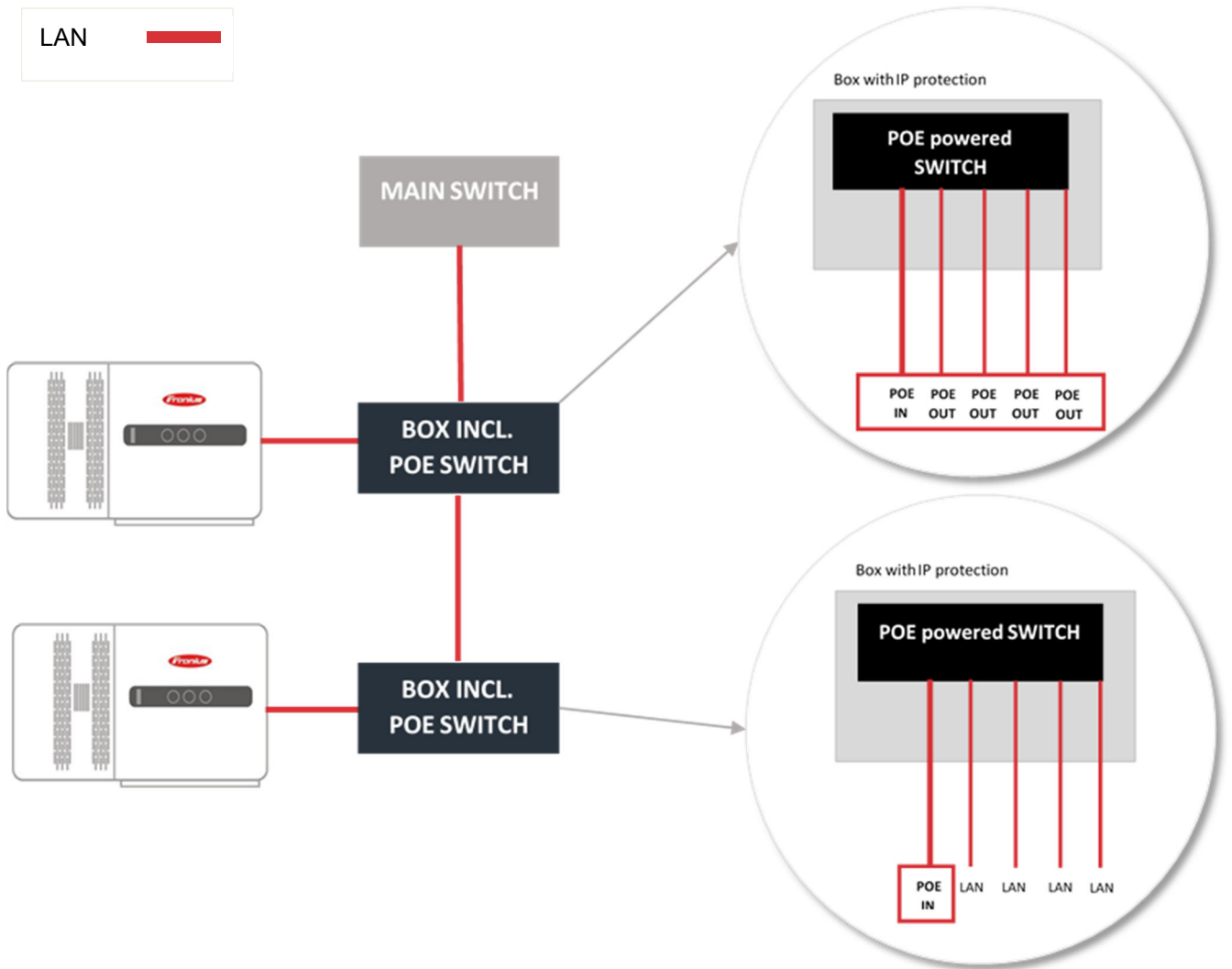

Picture 6: Different types of PoE switches within a chain

The first PoE switch in the system chain can forward the PoE signal to other switches and is therefore the middle part of the chain. The second one only has one input for "PoE IN". This type is the last switch within one chain. Please be aware that only a limited number of PoE switches can be daisy chained, due to the limited power transmission capacity over Ethernet. Also, the main switch (very first in the chain) needs to have a PoE OUT port.

5.3 Outdoor switch without PoE

Outdoor switches do not require any boxes, but the workload is greater due to the power supply. There are several different setup options for outdoor switches with the Fronius Tauro:

5.3.1 Supplied by 12 V output

The 12 V output of the Tauro's communication unit can be used to power the outdoor switch. This saves on external power adaptors and is quite easy to install. Please note the power limitations of the internal power supply.

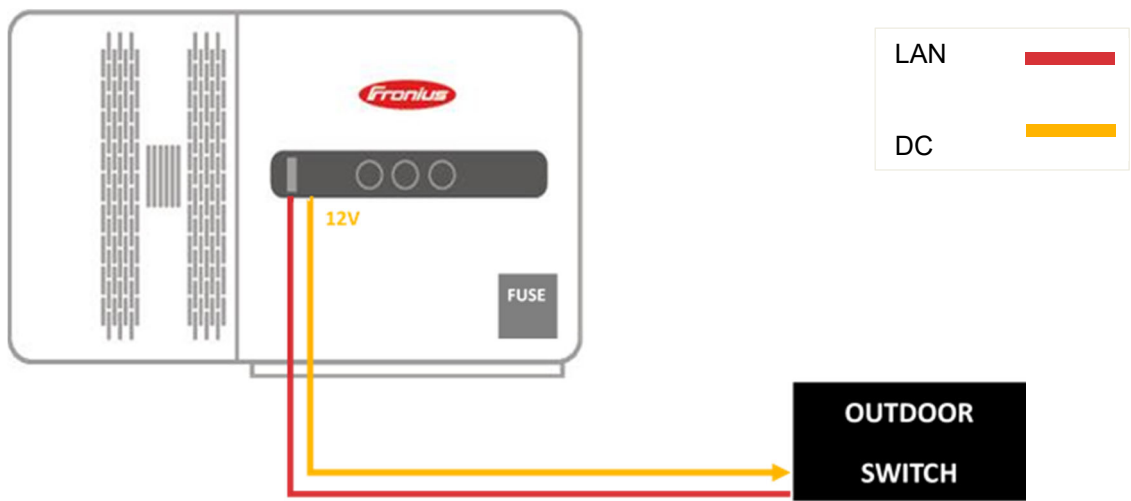

Picture 7: Outdoor switch supplied by 12 V output

5.3.2 Supplied by AC area

If the AC Daisy Chaining option is being used, the power supply can be drawn from the Tauro's AC area with fuse protection, if the outdoor switch also has its own power adaptor included. This solution saves on external boxes. Be careful to observe the temperature ratings of the inverter.

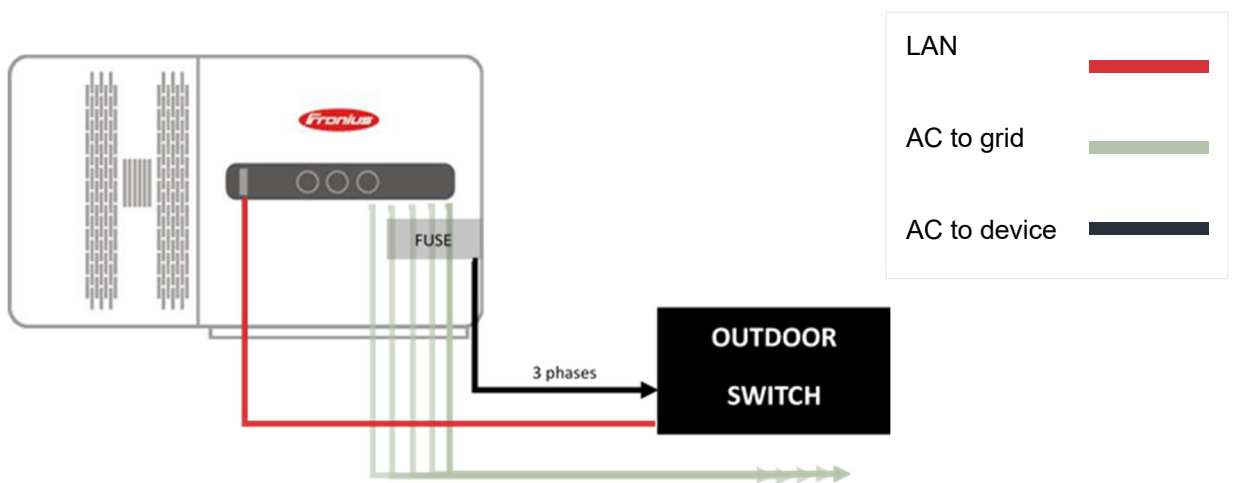

Picture 8: Outdoor switch supplied from AC area

5.3.3 Supplied from AC area (incl. power adaptor)

DC power can be drawn from the Tauro's AC area with fuse protection and a built-in power adaptor inside the Tauro for DC power if necessary. Only the DC power is then routed outside to the switch. This again avoids the need for an external box in which to house the switch. Be careful to consider the temperature ratings of the inverter.

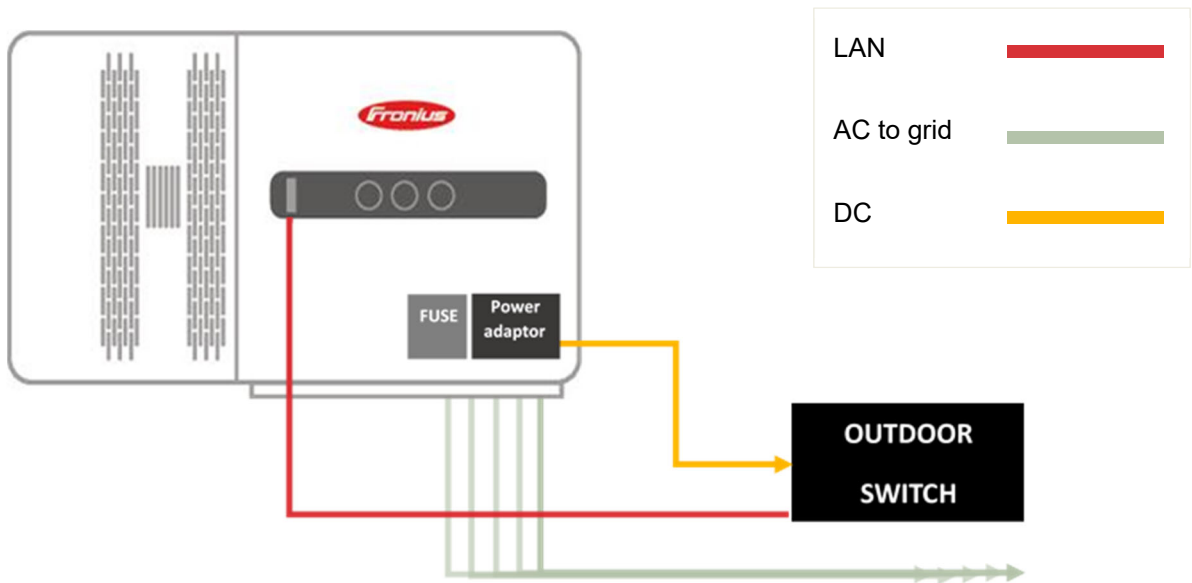

Picture 9: Outdoor switch supplied from AC area and power adaptor

5.4 Outdoor PoE switch

PoE switches are also available for outdoor installation and at a very reasonable price. Choosing the components requires very little effort. The switch is supplied by Power over Ethernet, therefore installation is very easy.

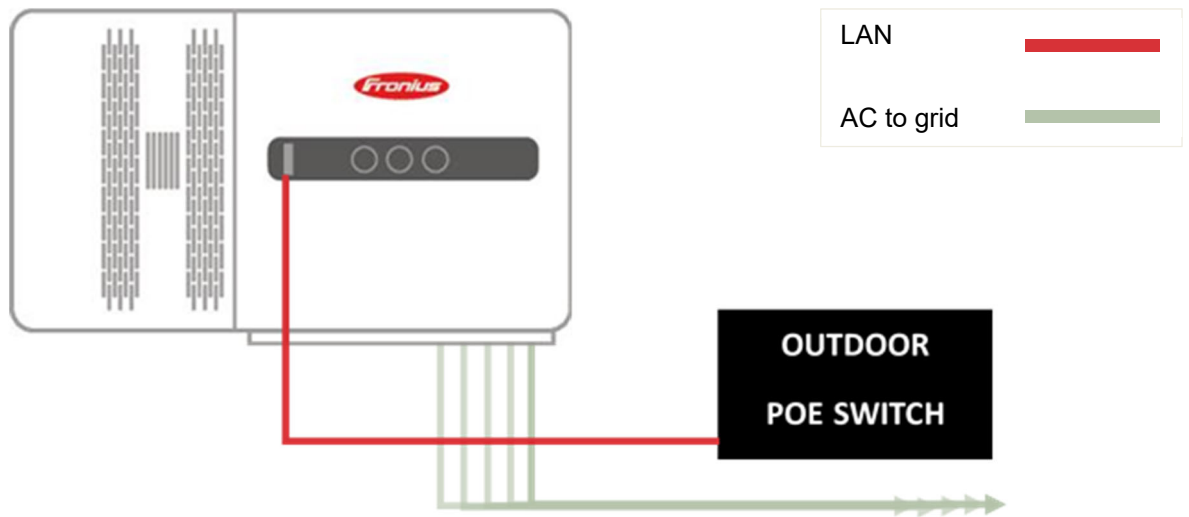

Picture 10: Outdoor PoE switch

5.5 Built-in switch inside the Tauro

Since the Fronius Tauro offers a generous connection area, it is possible to build in the switch inside the device! Switches installed in the connection area can be supplied with 12 V power from the Fronius Tauro's communication unit.

This easy space-saving solution saves on external components and thus costs, and also offers the same IP protection as the inverter itself. Please take care to consider the possible high temperatures inside the inverter when choosing the switch.

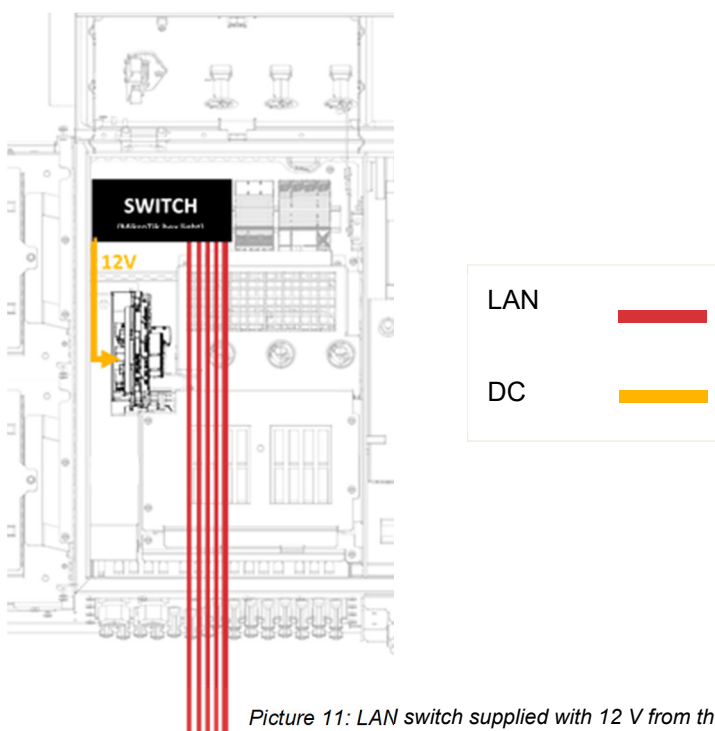

Picture 11: LAN switch supplied with 12 V from the Tauro's communication unit

5.6 Real life example – Tauro pre-series in Austria

The pictures below show our pre-series plant in Austria, where LAN switches were built into the connection area of the Fronius Tauro.

The installer chose this communication layout variant because it represented the lowest investment costs and the easiest placement in this plant.

Altogether three additional switches were used in this project to save cabling costs and workload, but also to ensure relatively low investment costs in the communication infrastructure.



Picture 12: Pre-series Austria LAN switch integrated by the customer



Picture 13: Pre-series Austria - another LAN switch integrated by the customer