



# E-Mobility Solutions

Intelligently charging an electric car at home with PV energy.

---

White Paper

© Fronius International GmbH

Version 1 05/2018

Fronius reserves all rights, in particular rights of reproduction, distribution and translation.

No part of this work may be reproduced in any way without the written consent of Fronius. It must not be saved, edited, reproduced or distributed using any electrical or electronic system.

You are hereby reminded that the information published in this document, despite exercising the greatest of care in its preparation, is subject to change and that neither the author nor Fronius can accept any legal liability.

Gender-specific wording refers equally to female and male form.



# CONTENTS

<b>1.</b>	<b>General information</b>	<b>4</b>
1.1	Fronius solutions	4
1.2	Domestic charging options for electric cars	4
1.3	Charging power	5
1.4	User behaviour & convenience (fear of long charging times)	6
<b>2.</b>	<b>Energy management with Fronius Datamanager 2.0</b>	<b>7</b>
2.1	General remarks	7
2.2	Essential equipment or materials	7
2.3	Mode of operation with connection to the digital output	7
2.4	Steps towards implementation	8
2.4.1	Step 1 – Wiring the different control options	8
2.4.2	Step 2: Establishing a connection to the inverter	10
2.4.3	Step 3: Applying load management settings on the web interface	11
2.5	Advantages and disadvantages of this solution	12
<b>3.</b>	<b>The Fronius &amp; eCharge cPH1 solution</b>	<b>13</b>
3.1	General remarks	13
3.2	Components required	13
3.3	Steps towards implementation	14
3.3.1	Step 1: Installation and connection	14
3.3.2	Step 2: Establishing a connection to the inverter	14
3.3.3	Step 3: Settings on the Fronius inverter	14
3.3.4	Step 4: Settings on the cPH1 wallbox	15
<b>4.</b>	<b>The Fronius, Loxone &amp; Keba solution</b>	<b>16</b>
4.1	General remarks	16
4.2	Components required	16
4.3	Steps towards implementation	16
4.3.1	Step 1: Installation and connection	16
4.3.2	Step 2: Establishing a connection to the inverter	17
4.3.3	Step 3: Settings on the Fronius inverter	17
4.3.4	Step 4: Settings on the Keba KeContact P30 wallbox	18
4.3.5	Step 5: Settings on the Loxone Miniserver	18
<b>5.</b>	<b>APPENDIX</b>	<b>18</b>
5.1	Using e-mobility solutions in combination with the Fronius Symo Hybrid	18



5.2	E-mobility solutions in combination with the Fronius Ohmpilot .....	19
5.3	Fronius Datamanager 2.0 Software Version 3.2.2 (or older) .....	19
5.4	Remote control .....	20
5.5	Examples of relay types .....	20
5.6	Further information .....	20

## 1. GENERAL INFORMATION

"Producing your own fuel for your own car." It sounds like a futuristic dream, but at Fronius, this is already a reality. Such a solution is made possible through a combination of electric car, photovoltaic system and intelligent charging control.

This paper focuses on the aspect of intelligent charging control. In addition to the general principles of charging electric cars at home, it will also set concrete solutions for intelligently charging electric cars with photovoltaic energy.

### 1.1 Fronius solutions

As per the demands and wishes of its clients, Fronius offers a number of solutions for intelligently charging electric cars in combination with a photovoltaic system. Essentially, this means distinguishing between simple charging control (including charging management), and continuous charging control (including charging management).

#### Simple solutions:

- / **Energy management with Fronius Datamanager 2.0**
- / **Control of a socket**
- / **Control of a Keba wallbox**
- / **Control of a eCharge wallbox**

#### Continuous solutions:

- / **The Fronius & eCharge cPH1 solution**
- / **The Fronius, Loxone & Keba solution**

The simple solution boasts low investment costs with a rapid payback time and is recommended in most cases, but particularly with small photovoltaic systems ( $\leq 5$  kWp) or where consumers only have a small charging capacity (such as electric lawnmowers, electric bikes, etc.) (see chapter "2. Energy management with Fronius Datamanager 2.0").

Continuous solutions allow for a higher rate of self-consumption, especially with larger PV systems, thanks to their better utilisation of PV surpluses (see chapter "3. The Fronius & eCharge cPH1 solution" and chapter "4. The Fronius, Loxone & Keba solution").

### 1.2 Domestic charging options for electric cars

Domestic charging is currently restricted to AC charging. At the moment, DC charging is only used at charging stations with a high charging output, which are both economically unviable and unnecessary in a domestic setting. In relation to AC charging, there are two charging setups: one with an ICCB cable (In Cable Control Box) and one with a wallbox.

With an ICCB cable (see Figure 1), protection functions and communication with the electric car is integrated into a box in the cable (see Figure 1). The ICCB cable connects the socket in the home to the electric car. Depending on the plug used in the domestic socket, single-phase or three-phase charging may be performed. A CEE Cara socket is recommended for single-phase charging (up to a maximum of 3.7 kW), as an earthed (Schuko) socket is not suitable for excessive long-term usage. In terms of three-phase charging, CEE 16 A and CEE 32 A sockets are common.

A wallbox can be used as an alternative to an ICCB cable (see Figure 2 and Figure 3). Wallboxes are static installations, with protection and communication functions being integrated into the wallbox itself. Functions such as RFID (for authentication) and communications standards such as OCPP (e.g. for billing) mean that wallboxes offer additional benefits, which are also applicable in semi-public or public domains. Depending on the model, wallboxes are available with a fixed cable or a plug.

There are two types of socket used on electric cars: Type 1 and Type 2. It is important to select the right plug for the electric car when purchasing a wallbox or ICCB cable.



Figure 1: Charging cable (ICCB)  
Source: [www.nrgkick.com](http://www.nrgkick.com)



Figure 2: Keba KeContact P30 wallbox;  
Source: [www.keba.com](http://www.keba.com)



Figure 3: eCharge cPH1 wallbox  
Source: [www.eCharge.de](http://www.eCharge.de)

### 1.3 Charging power

Communication between the wallbox or ICCB cable and electric car is regulated according to IEC 61851. This standard only allows a very rudimentary kind of communication between the components. As well as determining the state of charge, the ability to start or stop charging and to specify a maximum charging current is the only information that may be exchanged.

The wallbox regulates the charging power of the electric car by setting a maximum charging current. The electric car receives this specification from the wallbox and adjusts the actual charging current accordingly. The speed and precision at which the target specification from the wallbox is met by the car depends on the car manufacturer. However, the stabilisation time is usually just a few seconds and the target value deviations are somewhere in the region of 100 W.

The target value for the charging current is also restricted to a range between 6 A and 80 A (as defined by the standard). It is not possible to set a value between 0 A and 6A. Charging is either suspended or set at a minimum of 6 A. If we convert current into power, a minimum charging power of 1.38 kW is generated during single-phase charging. For three-phase charging, the minimum charging power is 4.14 kW.

These lower limits for charging power impede the regulation of electric car charging according to the PV surplus, especially with small PV systems. This problem is clarified below with the help of a 5 kWp PV system combined with a three-phase electric car charging setup.

The maximum surplus power of a 5 kWp system is usually less than 4 kW. Amongst other reasons, this is normally to do with other loads in the house. Continuous electric car charging therefore has to take place between the control range of 0 and 4 kW. However, three-phase charging can only start at 4.14 kW, which is why continuous regulation does not make sense. For three-phase charging devices with small PV systems (~5 kW), we therefore recommend an energy management solution with the Fronius Datamanager 2.0, whereby the charging process will be simply started and stopped.

For single-phase connected charging devices, the control range starts at 1.38 kW. This means that continuous regulation is also attractive for smaller PV systems. Single-phase charging does, however, have a downside in the sense that the maximum charging power is significantly less than with three-phase charging (e. g. 3.7 kW at 16 A). This charging power is too low for rapid charging, which is why wallboxes are mostly connected in a three-phase setup.

**Note:** Certain electric cars, especially older models, require higher minimal currents (e.g. 12 A). This means that the control range for the charging power starts at higher values (e.g. single-phase: at 2.76 kW). Not every electric car supports three-phase charging. All charging variants are indeed available on the market. There are electric cars that can be charged through single-, two- and three-phase setups.

## 1.4 User behaviour & convenience (fear of long charging times)

The experiences of electric car and photovoltaic system owners show that low charging power at home is usually sufficient and even offers many benefits. Essentially, charging options for private usage can be reduced to three variants without affecting convenience and the importance of "having enough charge in the mornings":

Table 1: Suggestion of three charging options for private usage

Charging option	Location	Charging power
AC charging - charging optimised for self-consumption	At home	1.4 to 4.6 kW*
AC charging - rapid charging	At home	4.6 kW**
Acute DC charging	Service station	Max. charging power***

\*With 5 kWp PV system size

\*\*This value may even be higher, if required

\*\*\*Depending on car and charging station

New cars with relatively high ranges (e.g.: >250 km) offer sufficient reserves, even after long stretches of activity (e.g.: 100 km), to make an evening drive out possible without any concerns. Acute rapid charging is not usually necessary. Electric cars can be charged overnight at low charging power or optimally charged using surplus power.

In truly urgent cases, there is already a relatively wide network (depending on the region) of DC rapid charging service stations where you can transfer large amounts of energy in a short time. The owner simply takes the car to a service station, just like a conventionally fuelled car, and charges the electric vehicle in just a few minutes.

Low charging power with relatively long charging times has several benefits, in the sense that PV self-consumption is better utilised and the entire charging infrastructure (grid, home connection, charging device, electric car) is not under so much pressure. This preserves the car battery and extends its service life.

First and foremost, energy costs can be reduced by increasing the proportion of self-consumption. In future, domestic grid tariffs will also be power-dependent. A consequence of this is that high charging power would lead to significantly higher energy costs. By taking advantage of variable energy tariffs, electric cars can be consciously charged at times when cheap energy tariffs are in effect (possible with the target time specifications on the Datamanager 2.0 (see chapter 2)).

## 2. ENERGY MANAGEMENT WITH FRONIUS DATAMANAGER 2.0

### 2.1 General remarks

Intelligently controlling a charging socket or wallbox with a Fronius inverter (energy management function) is a simple and cost-effective way of raising PV self-consumption. The digital output of the inverter activates a socket or wallbox once a preset PV power or PV surplus threshold value is reached, thereby enabling daytime charging. Safety charging (which can be set by specifying a target time on the inverter) makes it possible to ensure a sufficient level of charge even on days with poor weather conditions or if charging is started later than usual. This method of charging to guarantee a specific range can also be used to specially activate charging of the electric car at times when energy tariffs are less expensive. An example of how an electric car can be charged with the help of the Fronius Datamanager 2.0 energy management system is presented in Figure 4.

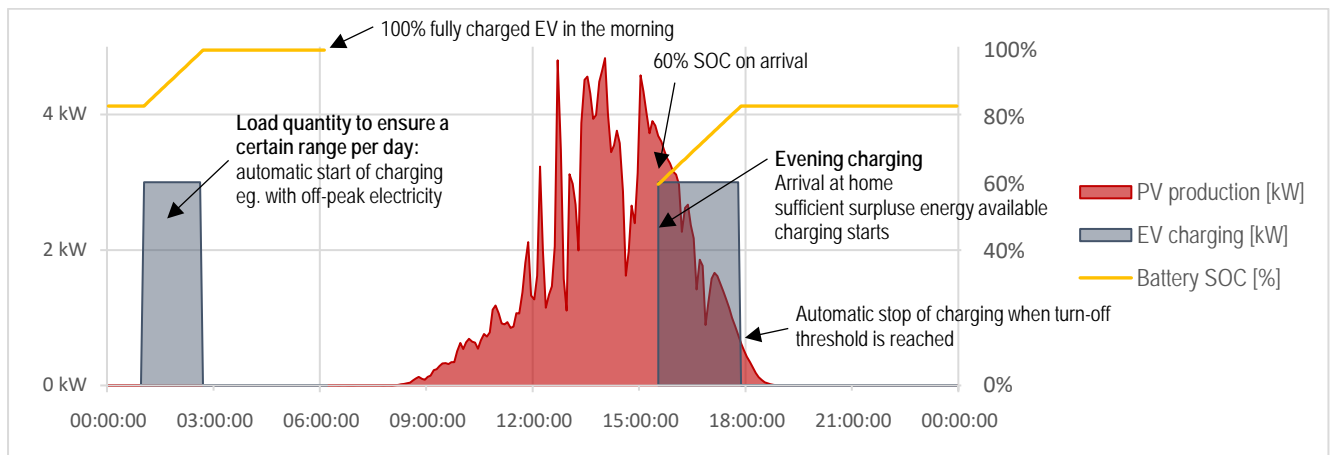

Figure 4: Example of an evening charge (from 4pm) with Fronius Datamanager 2.0 energy management. Total charge: 10 kWh (approx. 60 km). PV size: 6 kW. Electric car battery capacity: 30 kWh. Cloudy day.

The charging socket or wallbox can be energised with PV power or PV surplus power. A Fronius Smart Meter must be connected to the inverter in order to enable control using PV surplus power.

### 2.2 Essential equipment or materials

- Fronius inverter (Fronius IG, Fronius IG Plus, Fronius IG TL, Fronius Galvo, Fronius Primo, Fronius Symo) with integrated Fronius Datamanager 2.0 (essential!)
- Fronius Smart Meter (63 A-3, 63 A-1, 50 k-3) for PV surplus detection
- 12 V electrical isolation relay (max. 3.2 W coil capacity) (see appendix for technical data)
- Corresponding socket with ICCB charging cable or wallbox with charge-release input

### 2.3 Mode of operation with connection to the digital output

The charging socket is activated by the digital energy management output of the inverter (on the Fronius Datamanager 2.0). This is option 1.

Wallboxes that have a corresponding input (release input) can also be controlled in the same way thanks to Fronius load management. The Keba KeContact P30 wallbox and the eCharge cPμ1 wallbox are examined in detail (options 2 and 3).

For all three options, load management is adjusted on the Fronius inverter's web interface by setting threshold values and target running times (see step 3).

## 2.4 Steps towards implementation

Implementing the "Energy management with Fronius Datamanager 2.0" solution involves three steps. Step 1 can take the form of three different options:

- Option 1: Socket
- Option 2: Keba KeContact P30 wallbox
- Option 3: eCharge cPμ1 wallbox

The method of connecting to the Fronius Datamanager 2.0 is the same for all variants. It requires "IO 1" and "Gnd -" on the hardware interface of the Fronius Datamanager 2.0 (see Figure5).



Figure5: Connection on the Fronius Datamanager 2.0 for energy management.

### 2.4.1 Step 1 – Wiring the different control options

#### Option 1: Connecting the external relay for controlling the charging socket

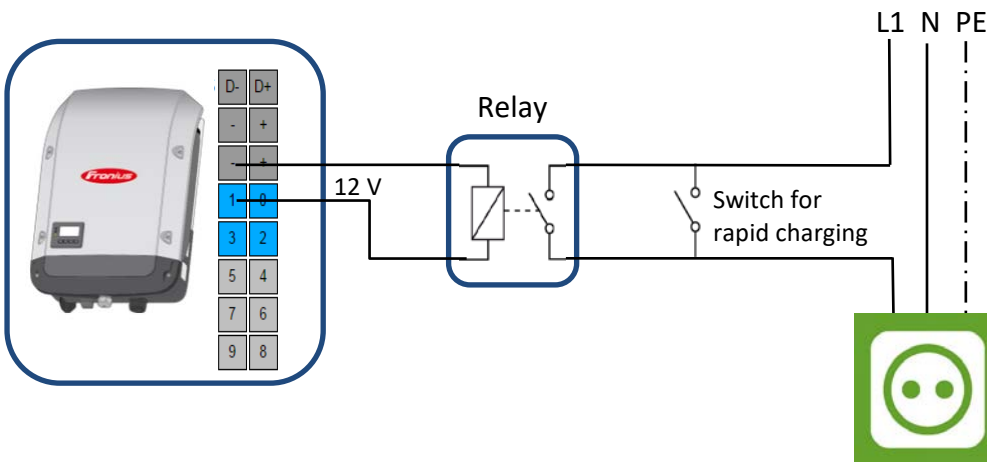

Figure 6: Connection diagram of the external relay for controlling a charging socket. Single-phase connector shown (three-phase also possible).

In order to control a socket, an external 12 V relay switches between IO 1 and Gnd, which in turn switches the charging socket in the garage on and off (see appendix 5.4 for guidance on relay selection). We recommend that a rapid-charging switch is installed parallel to the relay in the garage (see Figure 6). A CEE Cara socket (16 A, single-phase) can be used, but three-phase implementation with a CEE three-phase socket is also possible.

Note: The rapid-charging switch can also be placed between the Datamanager 2.0 and the relay. In this case, the switch is positioned parallel to the "IO 1" cable and between "+" and the relay. This configuration has the advantage that the switch does not have to switch the charging power of the electric car, but it may result in higher cabling costs.



**Option 2: Connection via the release input on the Keba KeContact P30 wallbox**

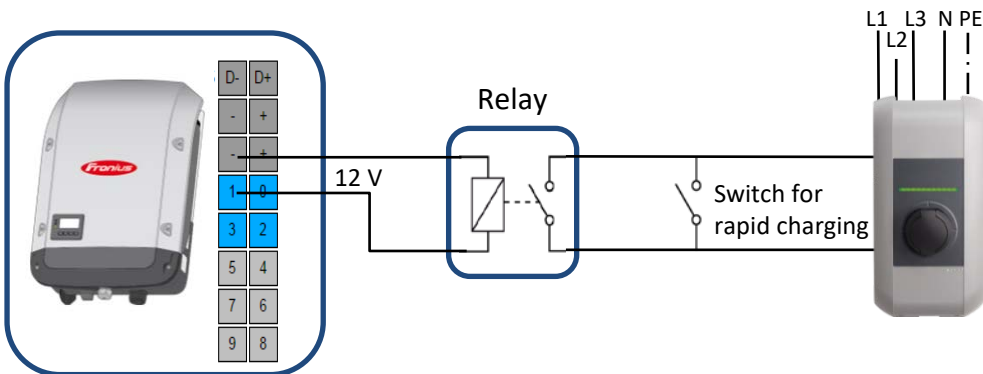

Figure 7: Connection diagram of the external relay for controlling the release input on the Keba wallbox. Three-phase connected wallbox shown (single-phase also possible).

Like a socket, the Keba wallbox can be controlled by the energy management function of the Fronius Datamanager via the release input. Once again, placing a switch parallel to the relay directly in the garage is recommended for rapid charging. The charging power is set using the dip switches when installing the wall box and remains unaltered when switching between rapid charging and PV charging.

In contrast to the socket, it is the release input rather than the phase that is locked or switched ready for operation. This has the benefit of not triggering any error messages on the electric car in the event that the charging process is frequently turned off and on (see chapter 2.5). The states of the charging release input are presented in Table 2. The release input must be enabled via an appropriate dip switch setting, which includes setting DSW1.1 to ON. The dip switches and terminals for the charging release input are shown in Figure 8.

Table 2: Logical function for the release contact

Release contact	State of the electric charging station
Open	LOCKED (not charging)
Closed	OPERATIONAL (ready to charge)

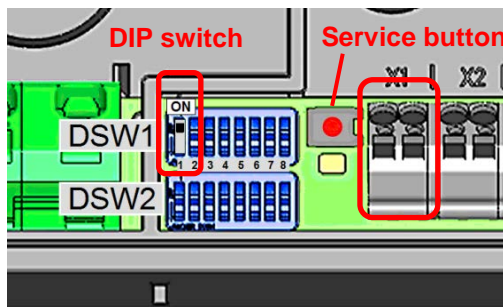

Figure 8: Dip switch settings for activating the release input; source: www.keba.com

Settings are applied once the wallbox has been restarted. To restart, press down the service button on the wallbox for one second.

For more precise information about installation and commissioning, see the Keba Installation Instructions: [www.keba.com](http://www.keba.com)

**Option 3: Connection via the release contact of the eCharge cPμ1 wallbox**

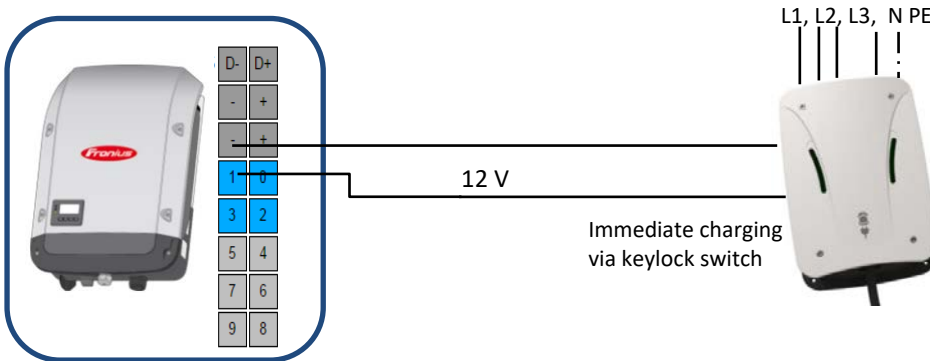

Figure 9: Connection diagram for controlling the eCharge cPμ1 wallbox. Three-phase wallbox shown (single-phase also possible).

Thanks to its keylock switch, the eCharge cPμ1 wallbox makes it possible to switch between three charging modes:

- ECO (control via energy management)
- Immediate charging
- Charging stop

To enable energy management via the Datamanager 2.0, the keylock switch must be set to "ECO". With the cPμ1, there is no difference in the maximum charging current in either "ECO" or "Immediate charging" mode. The eCharge wallbox is usually delivered with the desired maximum charging current already set. Should it be desirable to reduce the charging current after the wallbox has been purchased in order to optimise self-consumption, then this is effected through dip switches. Advice will need to be sought from the manufacturer in this instance.

The eCharge cPμ1 wallbox is controlled via a two-pin connection between the IO 1 and GND on the Datamanager and the keylock switch on the wallbox. A relay is recommended if the inverter and wallbox are relatively far apart. The detailed connection plan, with and without relay, as well as further information, is available from the wallbox manufacturer: [www.eCharge.de/](http://www.eCharge.de/)

**2.4.2 Step 2: Establishing a connection to the inverter**

Important: In order to establish a connection to the Fronius Datamanager menu, the end device in question (e.g. laptop, smartphone, tablet, etc.) must be set up as follows:

- "Obtain IP address automatically (DHCP)" must be activated

Procedure:

1. Select the menu item "SETUP" on the inverter display
2. Select the menu item "WiFi Access Point"

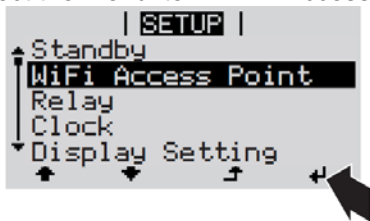

3. Connect the end device to the WiFi Access Point
  - a. On the end device, search for a network with the name "Fronius\_240.xxxxxx"
  - b. Establish a connection to this network
  - c. Enter password: 12345678
  - d. Enter <http://datamanager> or 192.168.250.181 (IP address of the WLAN connection) into the end device's browser. For a LAN connection, enter 169.254.0.180.

For further information relating to establishing a connection, see the Operating Instructions of the Fronius inverter or Fronius Datamanager 2.0.

### 2.4.3 Step 3: Applying load management settings on the web interface

As soon as a connection to the inverter has been established, "Load Management" [Lastmanagement] can be selected under "Settings" [Einstellungen] in the web interface. The energy management functions are described using an example and presented in Figure 10.

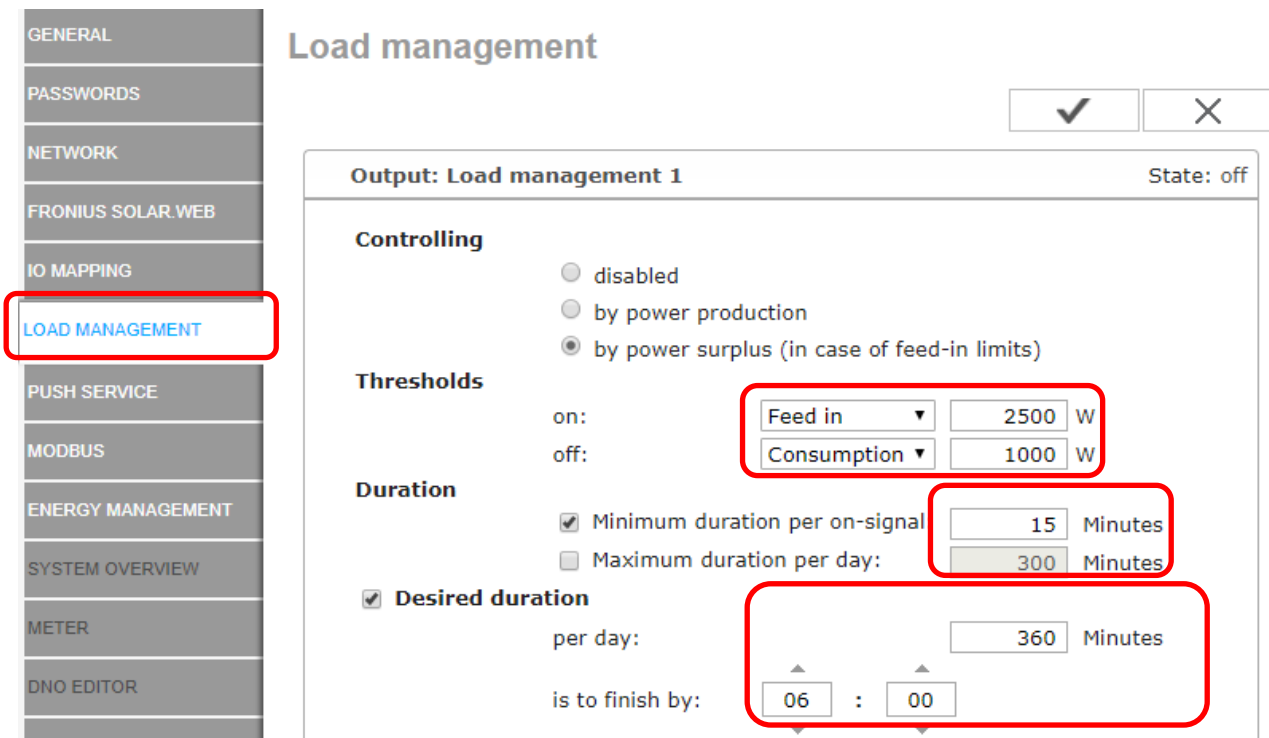

Figure 10: Electric car charging settings on the Fronius Datamanager web interface for load management. Setting of threshold values, minimum running time and target running time. Control can be governed by generated PV power or surplus power (only in conjunction with a Fronius Smart Meter).

#### Example:

An electric car is charged with 3,000 W of charging power in a single-phase setup. If the feed-in power of 2,500 W is exceeded, the IO 1 output of the Fronius Datamanager 2.0 is activated until an incoming supply of 1,000 W is measured at the feed-in point. Setting a minimum running time for each switch-on process (e.g. 15 min) prevents a constant switching on/off behaviour, but can lead to higher mains usage. Charging to ensure a certain range can be configured by setting the target time (e.g. 12am - 6am). This ensures that the car will be charged the next morning, even on very cloudy days. The threshold values also depend on the installed PV output, so the switch-on threshold value should not be more than 70% of the installed PV output.

When selecting the threshold values, it is also important to note that the difference between the switch-on and switch-off threshold values must always be greater than the charging power. In this example, the spread is 3500 W (1000 W incoming supply; 2500 W feed) and the charging power is 3000 W. If the charging power amounted to 4000 W, for example, the surplus power of 2500 W would jump to an incoming mains supply of 1500 W when charging was switch-on, meaning that the switch-off value would be immediately exceeded, and charging would be immediately halted again. This would result in the charging process being constantly switched on and off.

To calculate the minimum charging time according to charging power, see the following table (consumption of 17 kWh/100 km has been assumed and a mileage of 50 km and 100 km per day):



Charging power	Range after 1 hour	Charging period per day at 50 km of driving	Charging period per day at 100 km of driving
1.4 kW	8 km	6.2 h	12.3 h
2.3 kW	14 km	3.7 h	7.4 h
3.0 kW	18 km	2.8 h	5.7 h
3.7 kW	22 km	2.3 h	4.6 h
4.6 kW	27 km	1.8 h	3.7 h
7.4 kW	43 km	1.2 h	2.3 h
11 kW	65 km	0.8 h	1.5 h
22 kW	130 km	0.4 h	0.8 h

Table 3:

Estimation of range increase per hour and charging time with a consumption rate of 17 kWh/100 km.

## 2.5 Advantages and disadvantages of this solution

When using the Datamanager 2.0 for energy management, it is advisable to set the charging power based on the photovoltaic system, so that it is reached over a longer period of time and no energy needs to be obtained from the grid during days with high levels of insolation. For domestic applications, charging power is usually 2-4 kW. The wallbox manufacturers named here do not currently provide an easy way of setting a higher charging power for rapid charging than with PV charging. This means that customers need to trade a high level of self-consumption off against a relatively low rapid charging power.

If a socket is controlled with the Datamanager 2.0 and an ICCB cable with adjustable charging power is being used (e.g. nrgKick), the charging power can easily be adjusted on the ICCB cable. This makes it possible to raise the charging power for rapid charging, which presents a clear advantage in comparison with the wallbox solution. A disadvantage of this solution is that repeatedly switching the socket on and off within short periods of time can cause error messages to register on certain electric cars (currently a known phenomenon with one manufacturer).

### 3. THE FRONIUS & ECHARGE CPH1 SOLUTION

#### 3.1 General remarks

Continuous regulation of the charging power depending on the PV surplus power ensures the optimum level of self-consumption and can be realised with the help of the eCharge cPH1 wallbox. This solution also offers the advantage of easy installation. Wallbox settings, such as charging currents and charging modes, can be defined in a web interface, which also has a remote control function. Remote control is currently only possible through the web browser. In future, access will also be possible with an app on your mobile.

The eCharge cPH1 wallbox receives the operational data from the Fronius inverter and the Fronius Smart Meter via Solar API. The energy management function takes over the eCB1-LR PV controller that is integrated in the wallbox. Communication between the components takes place over the network. The eCharge cPH1 is connected to the network via Ethernet, whereas the Fronius inverter can be integrated into the network via Ethernet or WLAN.

Figure 11 shows an example of evening charging with the Fronius & eCharge cPH1 solution. In this example, the electric car is charged continuously according to the PV power. If the minimum charging power is not reached, charging will be continued at 1.4 kW until the electric car is fully charged.

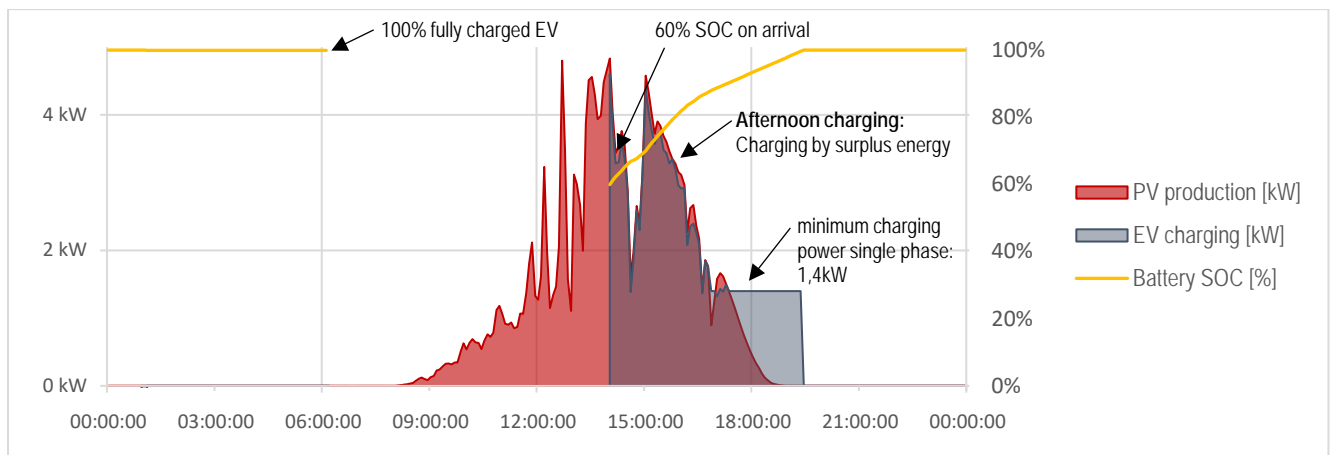

Figure 11: Example of an evening charge (from 4pm) with the Fronius & e-Charge cPH1 solution. Total charge: 12 kWh (approx. 70km). PV size: 6 kW. Electric car battery capacity: 30 kWh. Cloudy day.

Further information about charging modes, as well as installation and commissioning, can be obtained directly from the manufacturer: <http://echarge.de/>

#### 3.2 Components required

- Fronius inverter (Fronius IG, Fronius IG Plus, Fronius IG TL, Fronius Galvo, Fronius Primo, Fronius Symo) with integrated Fronius Datamanager 2.0 (essential!)
- Fronius Smart Meter (63 A-3, 63 A-1, 50 k-3) for PV surplus detection
- eCharge cPH1 wallbox
- DHCP server network

### 3.3 Steps towards implementation

#### 3.3.1 Step 1: Installation and connection

The system setup is shown in the diagram below.

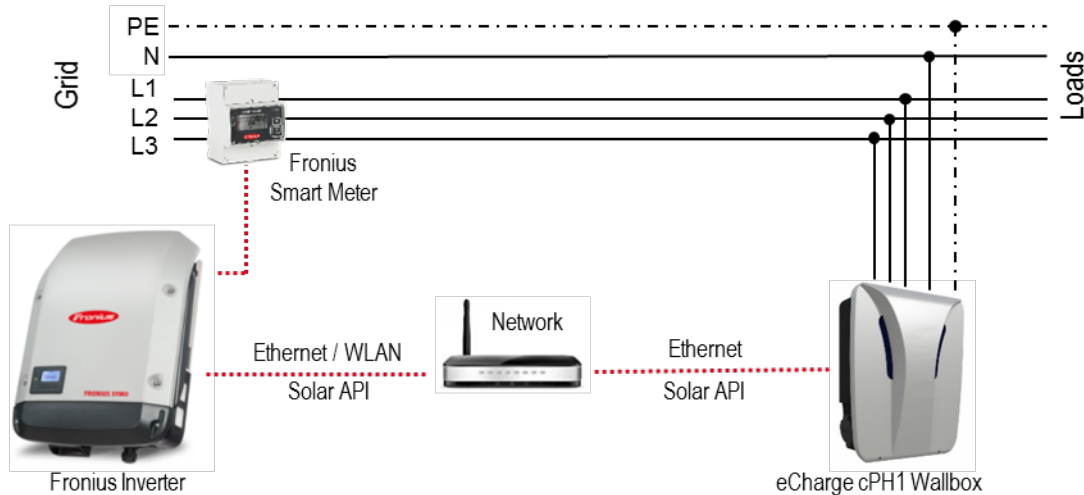

Figure 12: Communication diagram for the Fronius & eCharge cPH1 solution. Three-phase wallbox shown (single-phase also possible).

#### 3.3.2 Step 2: Establishing a connection to the inverter

Important: In order to establish a connection to the Fronius Datamanager menu, the end device in question (e.g. laptop, smartphone, tablet, etc.) must be set up as follows:

- "Obtain IP address automatically (DHCP)" must be activated

Procedure:

1. Select the menu item "SETUP" on the inverter display
2. Select the menu item "WiFi Access Point"

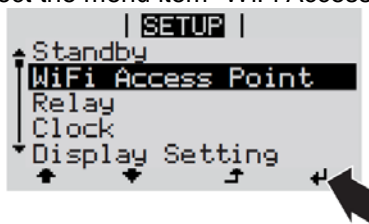

3. Connect the end device to the WiFi Access Point
  - a. On the end device, search for a network with the name "FRONIUS\_240.xxxxx"
  - b. Establish a connection to this network
  - c. Enter password: 12345678
  - d. Enter <http://datamanager> or 192.168.250.181 (IP address of the WLAN connection) into the end device's browser. For a LAN connection, enter 169.254.0.180.

For further information relating to establishing a connection, see the Operating Instructions of the Fronius inverter or Fronius Datamanager 2.0. ([www.fronius.com](http://www.fronius.com))

#### 3.3.3 Step 3: Settings on the Fronius inverter

##### Connecting to the network (WLAN/LAN):

So that the eCharge cPH1 wallbox is able to constantly receive data from the Fronius inverter, it is important not to change the inverter's IP address. We recommend a fixed IP address (IP binding) is assigned via the DHCP server (router) used in the network. The DHCP server recognises the inverter with the help of the IP binding and

always assigns the same IP address. It is important to make sure that the inverter's IP address is set to "Dynamic" under "Settings/Network" (see Figure 13). This ensures that the IP address is assigned by the DHCP server. It is also possible to assign a static IP address on the inverter without IP binding on the DHCP server. That can, however, lead to IP address conflicts. It is always a good idea to discuss this with the network administrator.

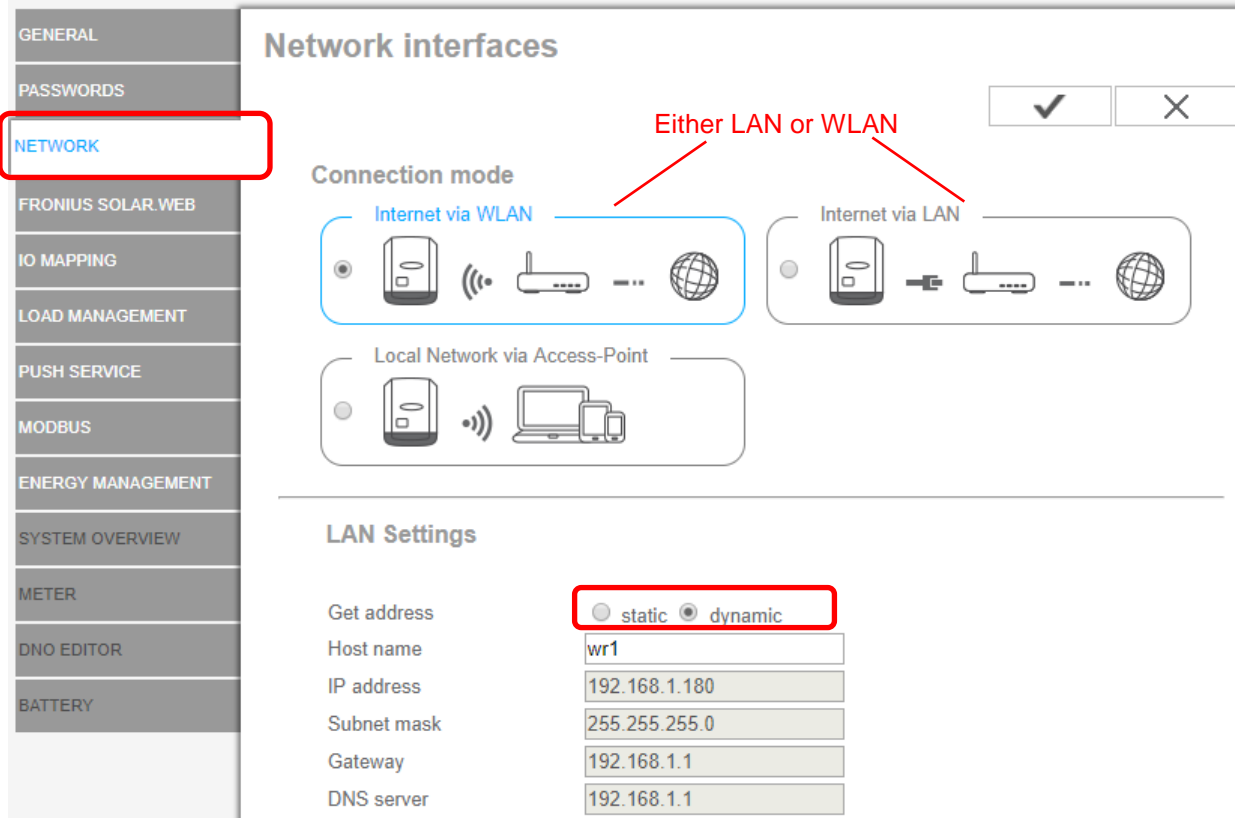

Figure 13: Diagram of the network settings based on WLAN. In case of a LAN connection, the same settings must be applied for LAN.

As soon as the inverter is connected to the network, the end device (computer, tablet, smartphone) needs to be connected to the same network in order to complete the setup process.

### 3.3.4 Step 4: Settings on the cPH1 wallbox

For more information about installation and proper commissioning, including connecting the Ethernet cable to the cPH1 wallbox, see the cPH1 wallbox Installation Instructions:

<http://eCharge.de/>

The essential points related to commissioning are summarised in the following checklist:

#### General:

- Proper installation of Fronius inverter (incl. Smart Meter) and wallbox.
- Wallbox and Fronius inverter are connected to the same network.
- The inverter's IP address remains the same in the network.

#### Software settings (eCharge wallbox):

- "Fronius measuring point" [Fronius Messpunkt] has been selected as the household connection measuring point.
- Household connection measuring point has been enabled and the IP address of the Fronius inverter has been entered.
- "eCB1 (internal)" [eCB1 (intern)] has been selected as the wallbox measuring point (socket measuring point).
- The wallbox measuring point has been enabled.
- "Phönix RTU" has been selected as the charge controller.
- The maximum connected load of the household connection has been set.

## 4. THE FRONIUS, LOXONE & KEBA SOLUTION

### 4.1 General remarks

Continuous regulation of the charging power based on the PV supply can be achieved by combining a Fronius "inverter", Loxone "miniserver" and a Keba KeContact P30 "wallbox".

The Loxone Miniserver receives operational data from the Fronius inverter or Fronius Smart Meter via Solar API. This information is processed in the Loxone Miniserver and then used to send the charging power specifications to the Keba wallbox. The Loxone Miniserver therefore performs the energy management function. Communication between the three components takes place over the network (WLAN/LAN). The Keba wallbox and Loxone Miniserver are connected to the network via Ethernet. The Fronius inverter can also be integrated into the network via Ethernet or WLAN (see Figure 14).

The exact name of the Keba wallbox is the Keba KeContact P30. It should be noted that the wallbox must be UDP-ready for the sake of communication, meaning only the c-series and the x-series are suitable here.

Knowledge and experience of network technology and the "Loxone Config" software is required to set up and connect components with "Loxone Config", as well as to program the energy management function. People who are not familiar with Loxone should allow for the time needed to train and get used to this tool in their initial project plans. In this respect we refer you directly to Loxone, who offer their own training courses for their products: [www.loxone.com](http://www.loxone.com)

### 4.2 Components required

- Fronius inverter (Fronius IG, Fronius IG Plus, Fronius IG TL, Fronius Galvo, Fronius Primo, Fronius Symo) with Fronius Datamanager 2.0 (essential!)
- Fronius Smart Meter (63 A-3, 63 A-1, 50 k-3) for PV surplus detection
- Loxone Miniserver
- Keba wallbox KeContact P30 (c-series or x-series, (UDP-ready))
- DHCP server network

### 4.3 Steps towards implementation

#### 4.3.1 Step 1: Installation and connection

The system setup is shown in the diagram below.

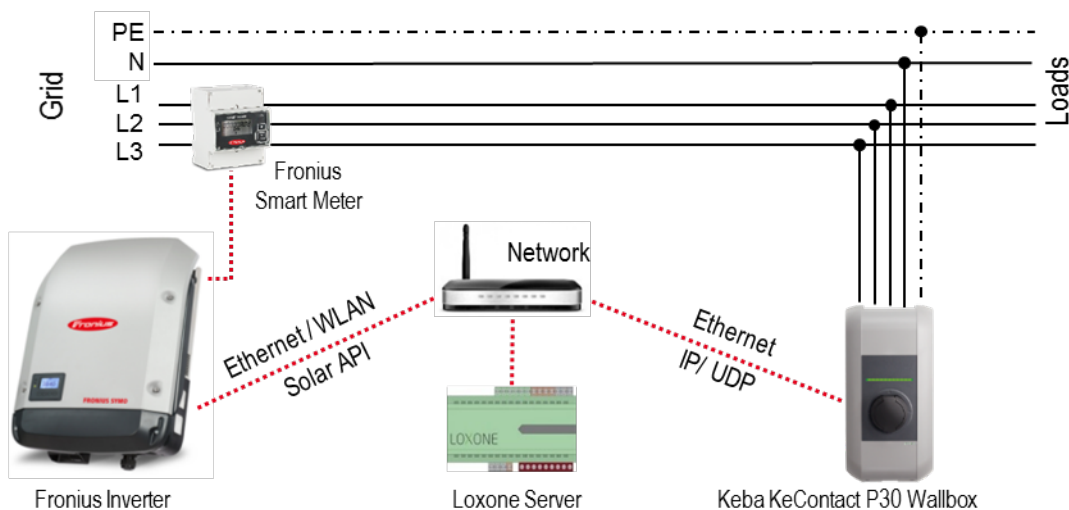

Figure 14: Communication diagram for the Fronius – Loxone – Keba system. Overview of a three-phase connected wall box (single-phase also possible).



### 4.3.2 Step 2: Establishing a connection to the inverter

Important: In order to establish a connection to the Fronius Datamanager menu, the end device in question (e.g. laptop, smartphone, tablet, etc.) must be set up as follows:

- "Obtain IP address automatically (DHCP)" must be activated

Procedure:

1. Select the menu item "SETUP" on the inverter display
2. Select the menu item "WiFi Access Point"

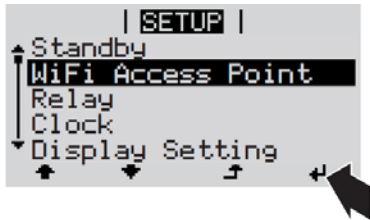

3. Connect the end device to the WiFi Access Point
  - a. On the end device, search for a network with the name "FRONIUS\_240.xxxxx"
  - b. Establish a connection to this network
  - c. Enter password: 12345678
  - d. Enter <http://datamanager> or 192.168.250.181 (IP address of the WLAN connection) into the end device's browser. For a LAN connection, enter 169.254.0.180.

For further information relating to establishing a connection, see the Operating Instructions of the Fronius inverter or Fronius Datamanager 2.0. ([www.fronius.com](http://www.fronius.com))

### 4.3.3 Step 3: Settings on the Fronius inverter

Network:

The screenshot shows the 'Network interfaces' configuration page. On the left is a sidebar menu with 'NETWORK' highlighted in a red box. The main content area has a title 'Network interfaces' and a status bar with a checkmark and an 'X' button. Below this, there are three connection mode options: 'Internet via WLAN' (selected with a radio button), 'Internet via LAN', and 'Local Network via Access-Point'. A red arrow points to the 'Internet via WLAN' and 'Internet via LAN' options with the text 'Either LAN or WLAN'. Below these is the 'LAN Settings' section, where the 'Get address' option has 'dynamic' selected (circled in red). Other settings include Host name: 'wr1', IP address: '192.168.1.180', Subnet mask: '255.255.255.0', Gateway: '192.168.1.1', and DNS server: '192.168.1.1'.

Figure 15: Diagram of the network settings based on WLAN. In case of a LAN connection, the same settings must be applied for LAN.



So that the Loxone Miniserver is able to constantly receive data from the Fronius inverter, it is important not to change the inverter's IP address. We recommend a fixed IP address (IP binding) is assigned via the DHCP server (router) used in the network. The DHCP server recognises the inverter with the help of the IP binding and always assigns the same IP address. It is important to make sure that the inverter's IP address is set to "Dynamic" [dynamisch] under "Settings/Network" [Einstellungen\Netzwerk] (see Figure 15). This ensures that the IP address is assigned by the DHCP server.

It is also possible to assign a static IP address on the inverter without IP binding on the DHCP server. That can, however, lead to IP address conflicts. It is always a good idea to discuss this with the network administrator.

As soon as the inverter is connected to the network, the end device (computer, tablet, smartphone) needs to be connected to the same network in order to complete the setup process.

#### **4.3.4 Step 4: Settings on the Keba KeContact P30 wallbox**

Please refer to the manufacturer, Keba, for information about installation and proper commissioning, including connecting the Ethernet cable to the Keba KeContact P30: <http://www.keba.com>

The following is a checklist containing the most important points relating to installing the solution.

##### **Checklist:**

- Proper installation of Fronius inverter (incl. Smart Meter), Keba wallbox and Loxone control.
- Wallbox and Fronius inverter are connected to the same network.
- The IP address for the wallbox is permanently assigned (e.g. via IP binding).
- UDP interface on the Keba wallbox has been enabled.
- Newest software version for the Keba wallbox is installed.
- The maximum charging current has been correctly set using the dip switch.
- Commissioning has been completed and the wallbox has been restarted before the first use in order to apply all the settings.

#### **4.3.5 Step 5: Settings on the Loxone Miniserver**

Please refer to the Loxone homepage for information about installing and commissioning the Loxone Miniserver, as well as installing the "Loxone Config" software: [www.loxone.com](http://www.loxone.com)

The "Loxone Config" software is needed to program the energy management function as well as to integrate the Fronius inverter and Keba wallbox. Tutorials on the Loxone homepage explain how to integrate the Keba wallbox: <https://www.loxone.com/dede/kb/keba-wallbox/>

## **5. APPENDIX**

### **5.1 Using e-mobility solutions in combination with the Fronius Symo Hybrid**

The solutions described in this paper are valid for all Fronius inverters with Datamanager 2.0 or an additional Datamanager 2 box.

The solutions carried out in chapter 2 "Energy management with Fronius Datamanager 2.0" are also possible with the Fronius Symo Hybrid inverter. It should be noted, however, that in the load management settings, instead of "per surplus power", control "through PV power" must be selected (cf. chapter 2.4.3 and see Figure 16).

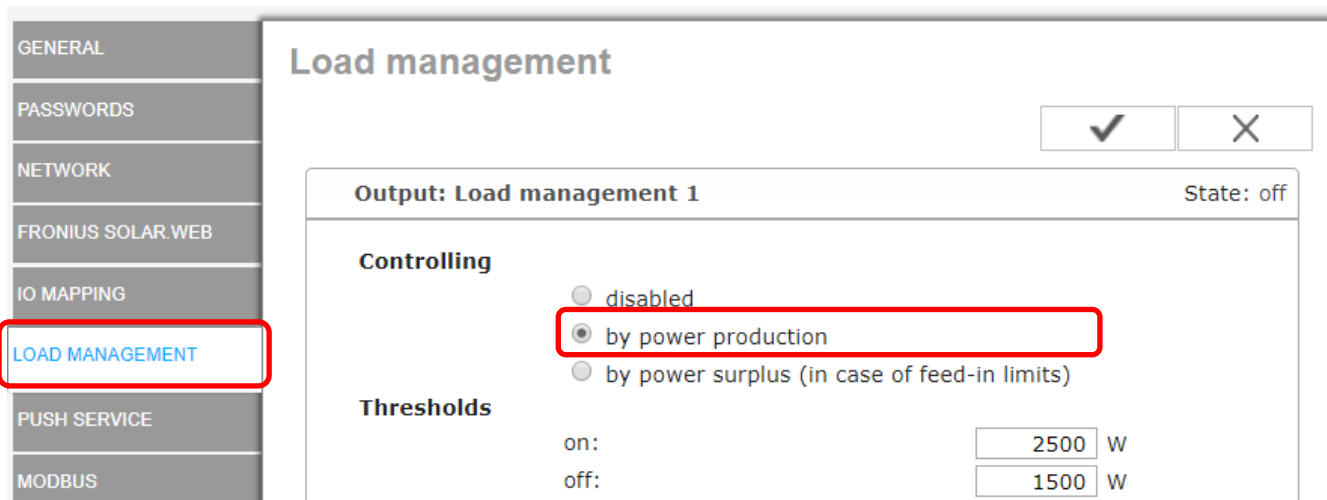

**GENERAL**

**PASSWORDS**

**NETWORK**

**FRONIUS SOLAR.WEB**

**IO MAPPING**

**LOAD MANAGEMENT**

**PUSH SERVICE**

**MODBUS**

## Load management

✓ ✕

**Output: Load management 1** State: off

**Controlling**

disabled

by power production

by power surplus (in case of feed-in limits)

**Thresholds**

on:  W

off:  W

Figure 16: Electric car charging settings on the Fronius Datamanager web interface – Load Management. Control must take place via the PV power generated when Fronius Datamanager 2.0 energy management is combined with the Fronius Energy Package.

Continuous energy flow management with the eCharge cPH1 (cf. Chapter 3) is also possible in combination with the Fronius Energy Package. This means that an electric car can be charged during the day directly from the PV system, or by immediate charging from the grid (no power is drawn from the battery at all). After sunset, charging then continues at the adjustable minimum charging power from the battery. The settings for this are made through the wallbox web interface (normally 6-10 A per phase).

The "The Fronius, Loxone & Keba solution" option described in chapter 4 is fundamentally possible in combination with the Fronius Energy Package. When programming the controller, it must be ensured that no oscillatory response arises between the Loxone control and the Fronius Symo Hybrid. Additionally, it is also important to consider what takes priority between charging the solar battery and charging the electric car.

## 5.2 E-mobility solutions in combination with the Fronius Ohmpilot

When the eCharge cPH1 is used in combination with the Fronius Ohmpilot, the electric car is always prioritised by default. Only when the electric car cannot be charged (car is fully charged or not plugged in) and there is still a PV surplus available, will the Fronius Ohmpilot switch to controlling the heating element and begin heating water in the boiler. If also a Fronius Solar Battery is present, PV energy will be assigned according to the following priorities:

- 1st priority: charge electric car;
- 2nd priority: charge battery;
- 3rd priority: heat water via the Fronius Ohmpilot.

## 5.3 Fronius Datamanager 2.0 Software Version 3.2.2 (or older)

Please note that older Fronius Datamanager 2.0 software versions may have fewer functions. To obtain all the latest functions, it may be necessary to perform a software update. For more information, please see our homepage or follow the link below.

<https://www.fronius.com/>



## 5.4 Remote control

It is also possible to adjust the settings remotely using a PC, provided it is located in the same LAN network. Additionally, the static IP address in the network settings of the Fronius Datamanager must be used. This IP address can be saved in the browser, making it readily accessible. Some new WLAN routers also allow the URL <http://datamanager/> to be used.

An external IP address is necessary to access the system from outside of the LAN network. Please make enquiries with the appropriate IT administrator.

## 5.5 Examples of relay types

Most of the solutions described in chapter 2 require a relay. The following technical specifications must be observed when selecting an external relay: max. coil capacity 3.2 W, coil voltage 12 VDC, switching voltage 230 V and switching current 16 A.

The following are examples of appropriate types:

- Finder installations relay 20 A series 22.22 with 2 NO contacts for single-phase charging
- Finder installation contactor 20 A series 22.34 with 4 NO contacts for three-phase charging

## 5.6 Further information

Fronius inverter Installation Instructions / Operating Instructions	<a href="http://www.fronius.com">www.fronius.com</a>
Keba Installation Instructions / Operating Instructions	<a href="http://www.keba.com">www.keba.com</a>
Loxone Installation Instructions / Operating Instructions	<a href="http://www.loxone.com">www.loxone.com</a>
eCharge Installation Instructions / Operating Instructions	<a href="http://www.echarge.de">www.echarge.de</a>

Troubleshooting: Please read the Operating Instructions or call us on:

**Fronius International – Technical Support**

**[pv-support@fronius.com](mailto:pv-support@fronius.com)**

**+43 (7242) 241 5670**

Fronius reserves all rights, in particular rights of reproduction, distribution and translation. No part of this work may be reproduced in any way without the written consent of Fronius. It must not be saved, edited, reproduced or distributed using any electrical or electronic system. You are hereby reminded that the information published in this document, despite exercising the greatest of care in its preparation, is subject to change and that neither the author nor Fronius can accept any legal liability. Gender-specific wording refers equally to female and male form.