

Quick Guide: How to install a Fronius Smart Meter*

*Single phase or 3-phase Energy Meter

White Paper

© Fronius Australia Pty Ltd., VH

Version 1.0/2016

Fronius reserves all rights, in particular rights of reproduction, distribution and translation.

No part of this work may be reproduced in any way without the written consent of Fronius. It must not be saved, edited, reproduced or distributed using any electrical or electronic system.

You are hereby reminded that the information published in this document, despite exercising the greatest of care in its preparation, is subject to change and that neither the author nor Fronius can accept any legal liability

Gender-specific wording refers equally to female and male form.

1. GENERAL

Fronius Smart Meters are Energy Meters which can be used to measure consumption data of a site or for export limitation of a PV system with Fronius the SnapInverter range.

It measure the power flow to the loads or grid and feed the information via ModBus RTU / RS 485 communication to the Fronius Datamanager 2.0 (comes built-in in SnapInverters Galvo, Primo, Symo and Eco) or can be retrofitted to all other Fronius inverters).

This document describes how to install and set up the single phase or 3-phase Fronius Smart Meter.

The document about to set up export limitation with the Fronius Smart Meter can be found here:

http://www.fronius.com/cps/rde/xbcr/SID-830DDE66-908C73F5/fronius_australia/Quick_Guide_How_to_set_up_Export_Limiting_using_the_Fronius_Smart_Meter_1163209_snapshot.pdf

1.1 Location of the Fronius Smart Meter

With the Fronius Smart Meter there are 2 possible energy paths / locations where it can be installed. The **feed-in path** or the **consumption path**.

Feed-in path – bi-directional energy measurement. Load = Meter reading + Inverter power

Consumption path – single direction energy measurement. Load is measured directly.

Due to NET metering and the common way installations are done in Australia, in almost all cases, the Fronius Smart Meter will be installed in the **feed-in path**. This is also the default setting on the Datamanager METER tab.

/ Feed-in point

In this position the solar & the loads are in parallel. The solar is connected to the “load” side of the Fronius Smart Meter.

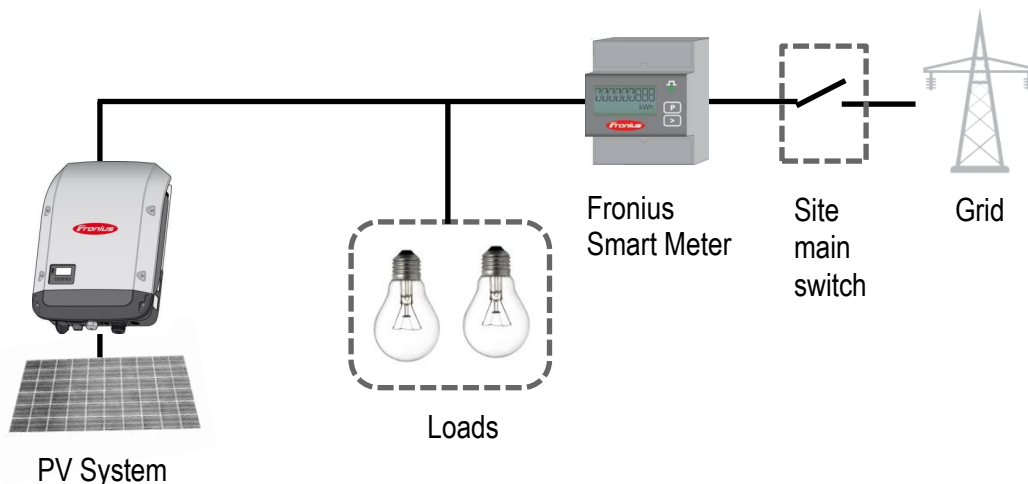

/ Consumption path

In this position the solar & the loads are separated by the meter. The solar is connected to the “grid” side of the Fronius Smart Meter.

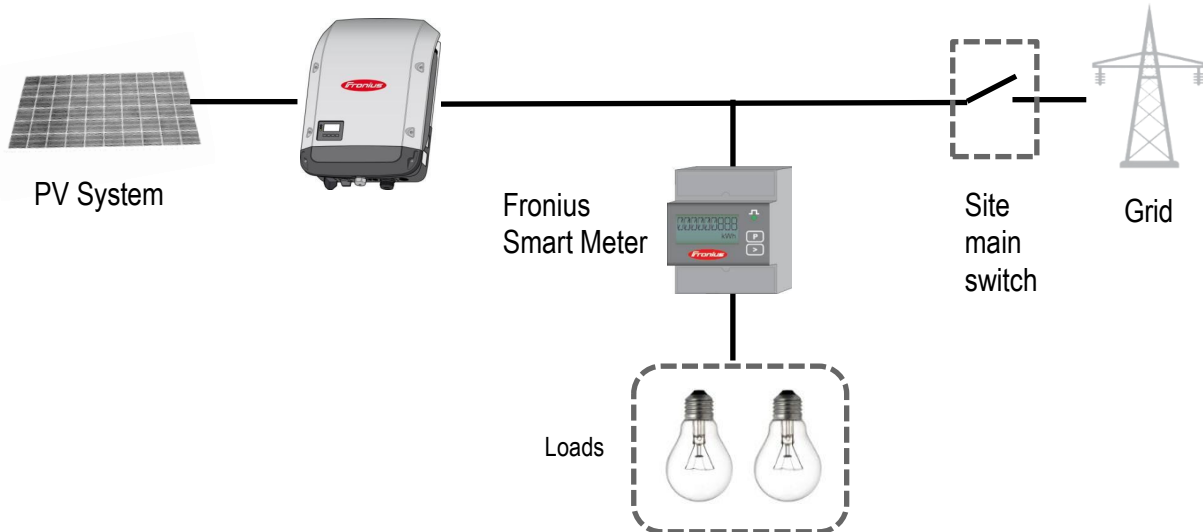

1.2 Requirements

Important! The Fronius Datamanager 2.0 needs a software version of **3.5.1-2** or greater. It can be downloaded from the Fronius Website under *Solar Energy/Info & Support/Software Downloads/Software Updates* or click here: http://www.fronius.com/cps/rde/xchg/SID-1CE5A97E-8EC72008/fronius_australia/hs.xsl/25_7671.htm

For more detailed information on how to upgrade the firmware of Fronius Datamanager 2.0 please see the Operating Instructions on the Fronius website under *Solar Energy / Products / System monitoring / Datalogging /Fronius Datamanager 2.0* or click: http://www.fronius.com/cps/rde/xbcr/SID-DBD64F5C-18F6818F/fronius_australia/42_0426_0191_EA_388899_snapshot.pdf

2. INSTALLING AND ACTIVATING A FRONIUS SMART METER

2.1 Intro

Fronius Smart Meters (single phase or 3-phase) are energy meters with ModBus RTU / RS 485 communication. It is needed for measuring the load and energy fed into the grid.

It is required to connect it to the Fronius Datamanager 2.0 (comes built-in in SnapINverters Galvo, Primo, Symo and Eco) and can be retrofitted to all other Fronius inverters.



2.2 Schematics and Wiring

The following schematics shows the system configuration

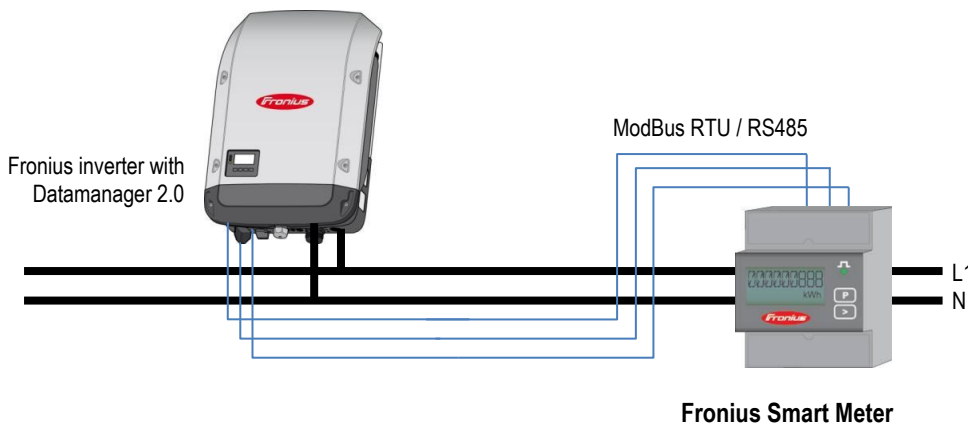

Please note:

- / Wiring between meter and inverter should use CAT5 or CAT6 cable (LAN cable)
- / Connection is a data line for Modbus RTU / RS485 using screw terminals on the meter
- / Maximum distance: 300 m (980 feet)

Meter connection on the Datamanager 2.0

The meter needs to be connected to the Datamanager's terminal block.

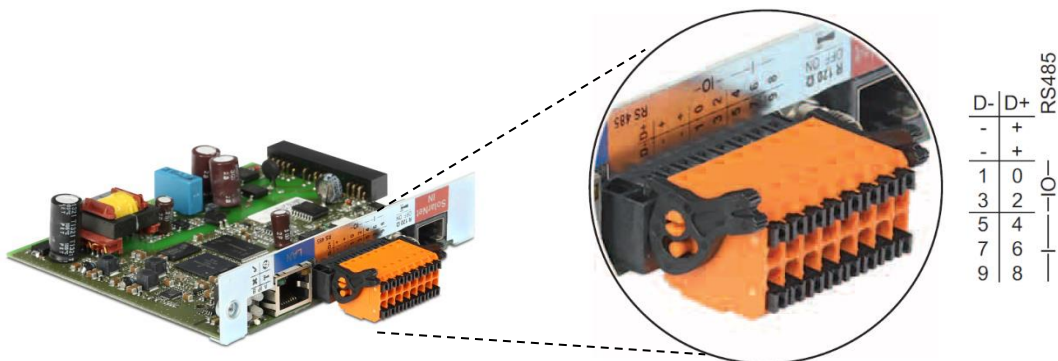

Wiring detail for Single Phase Fronius Smart Meter 63A/1PH* and Datamanager 2.0**

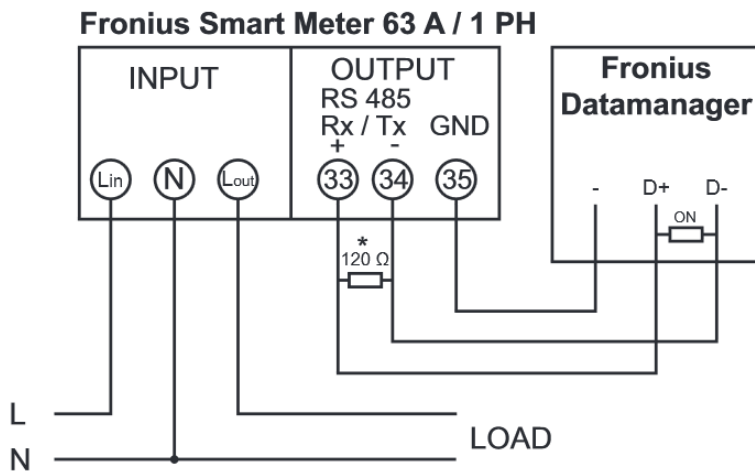

* The 120 Ohm terminating resistor is enclosed with the meter

*** Please note that the connections 33, 34, 35 on the Fronius Smart Meter are in the reverse order than shown in the graphics left!

Wiring detail for 3-Phase Fronius Smart Meter 63A/3PH and Datamanager 2.0

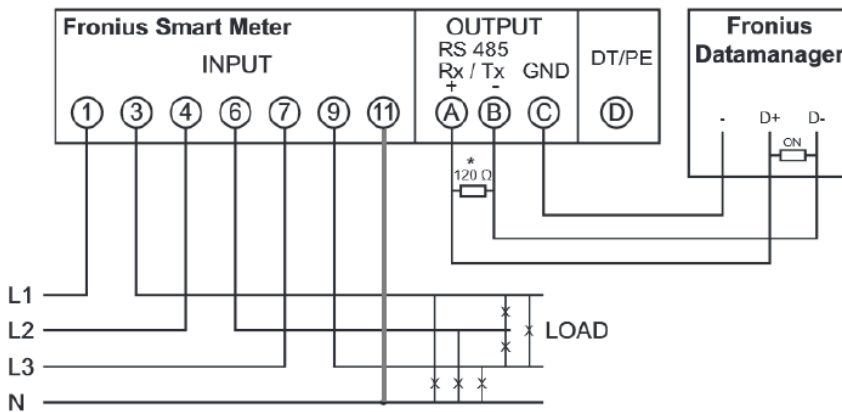

* The 120 Ohm terminating resistor is enclosed with the meter

Wiring detail for 3-Phase Fronius Smart Meter 50kA/3PH and Datamanager 2.0

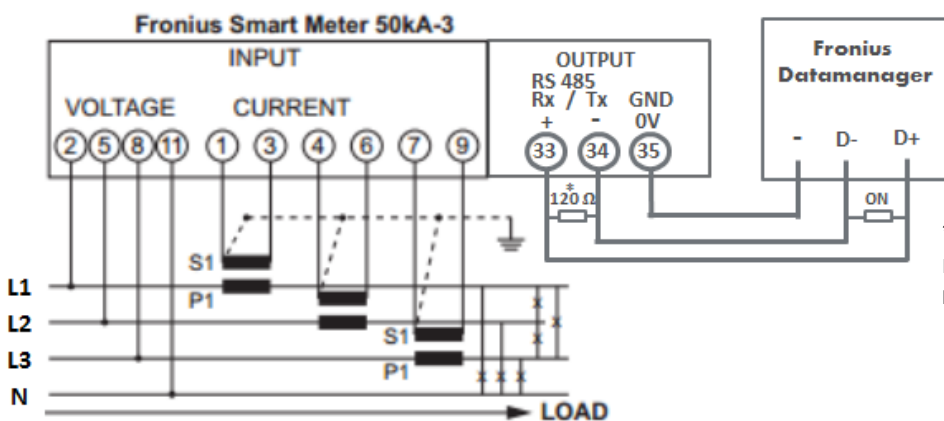

* The 120 Ohm terminating resistor is enclosed with the meter

Current transducers with a secondary current of 1A and 5A can be used.

Programming

Only the transmission ratio has to be set!

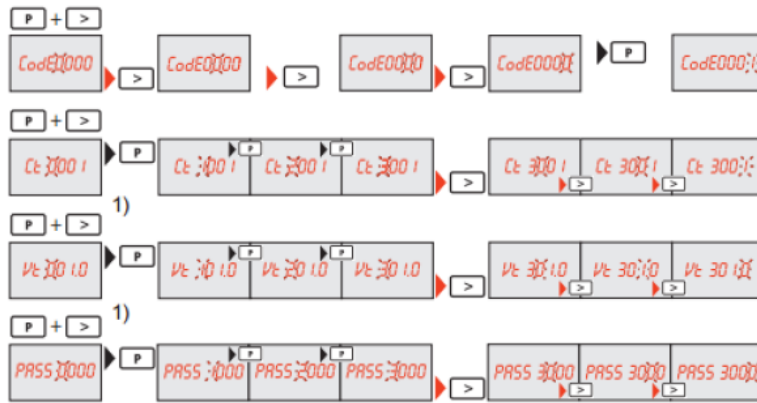

Password / type in Code 0001

transmission ratio of the current transducer
 *) If your CT ratio is 20 once set this will now read Ct 0020

transmission ratio of the voltage transducer – not in use.

Change password – 0001
 For future changes of the CT, please don't change the password, there is no possibility to read the set password

*) ratio Primary nominal current / secondary nominal current

Example:

Primary nominal current 100 A / secondary nominal current 5 A = Transmission ratio 20

Primary nominal current 200 A / secondary nominal current 5 A = Transmission ratio 40

Modbus termination switch on the Datamanager

The internal bus termination 120-Ohm resistance (for Modbus RTU) needs to be switched to ON.

Please Note:

The termination resistance must be activated for the first and last device in an RS-485 bus.



2.3 Activating the Fronius Smart Meter on the Datamanager web interface

The Datamanager Web interface can be accessed in two ways:

1. Via the Wi-Fi Access Point:
 - Activate the Wi-Fi Access Point on the Datamanager card (inverter) or Datamanager Box 2.0
 - Connect your computer/tablet/smart phone to the „Fronius_240.XXXXXX” Wi-Fi network
 - Open a web browser and go to <http://192.168.250.181>.
 Alternatively you can use Fronius SolarWeb App (Tablet/Smart Phone), go to 'Settings' and click 'PV Inverter Homepage' (IOS) or My System Monitoring (Android)
2. Via the LAN Port:
 - Connect your computer to the Datamanager via LAN cable
 - Switch the Datamanager IP Switch to Position 'A'
 - Open a web browser and go to <http://169.254.0.180>

For information of how to set up the Fronius Datamanager please see the manual of the Fronius inverter or the Fronius Datamanager (for Fronius Galvo/Symo/Primo/Eco):

http://www.fronius.com/cps/rde/xbc/SID-DBD64F5C-18F6818F/fronius_australia/42_0426_0191_EA_388899_snapshot.pdf

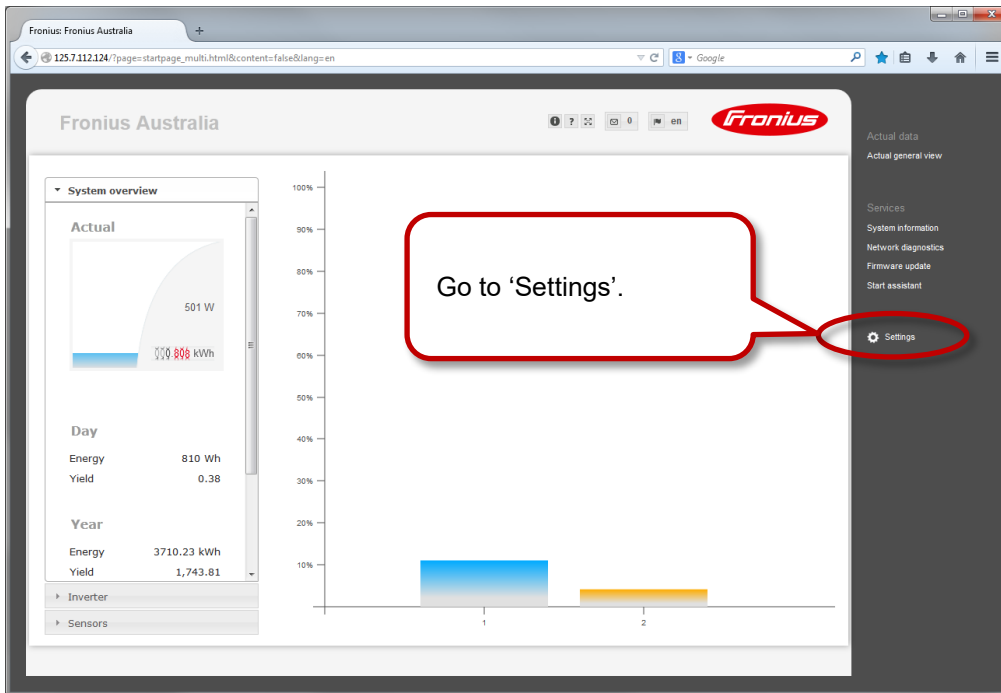

Before it is possible to enter the *METER* settings a service password is required. If no service password has been set, it needs to be created first!

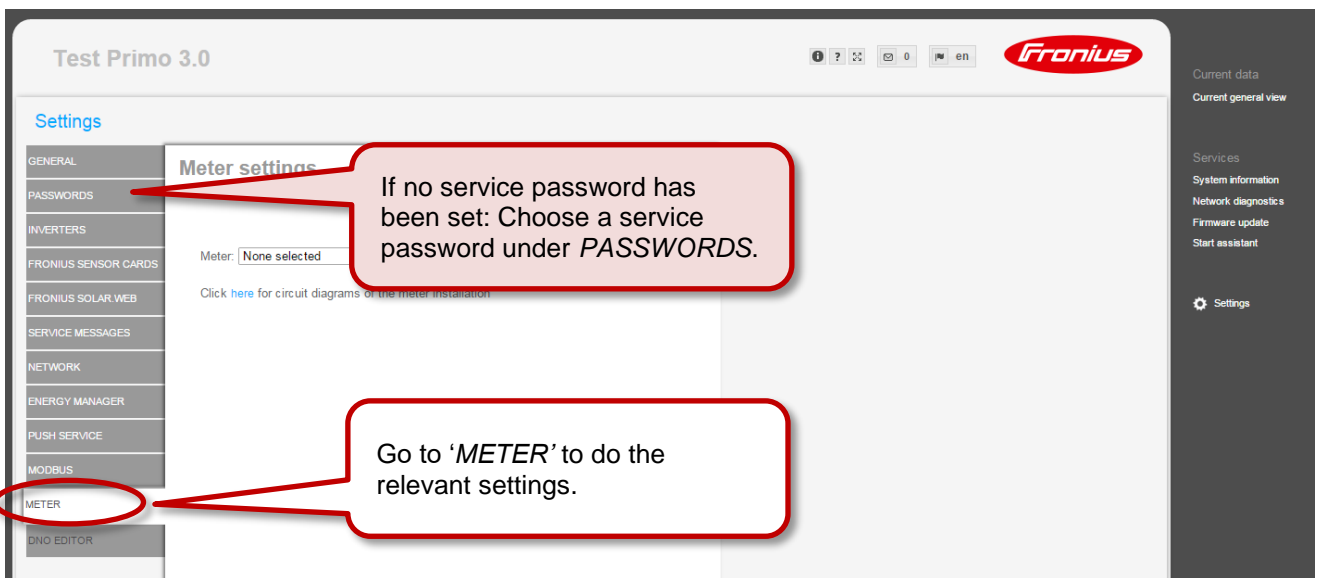

Choose the type of meter.

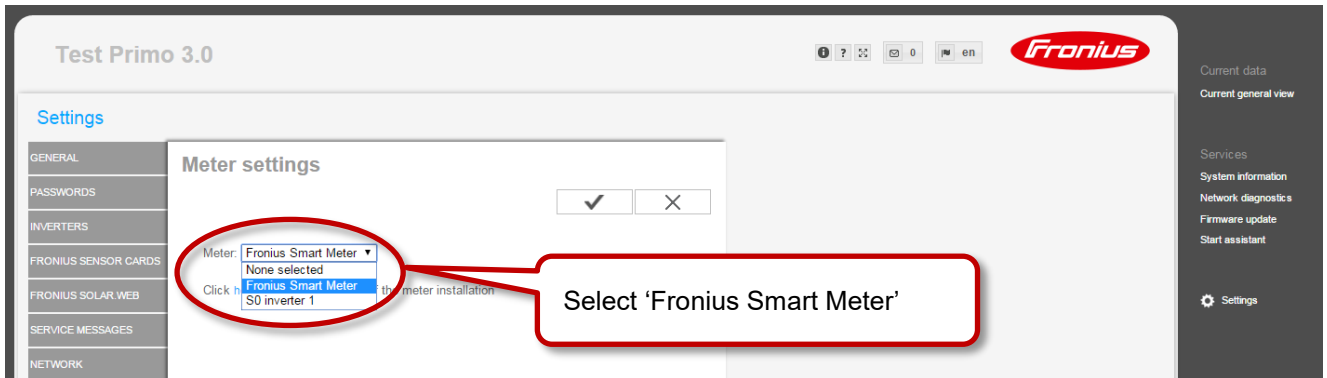

Choose location.

For further explanations on feed-in path and consumption path see chapter 1.1 *Location of the energy meter*

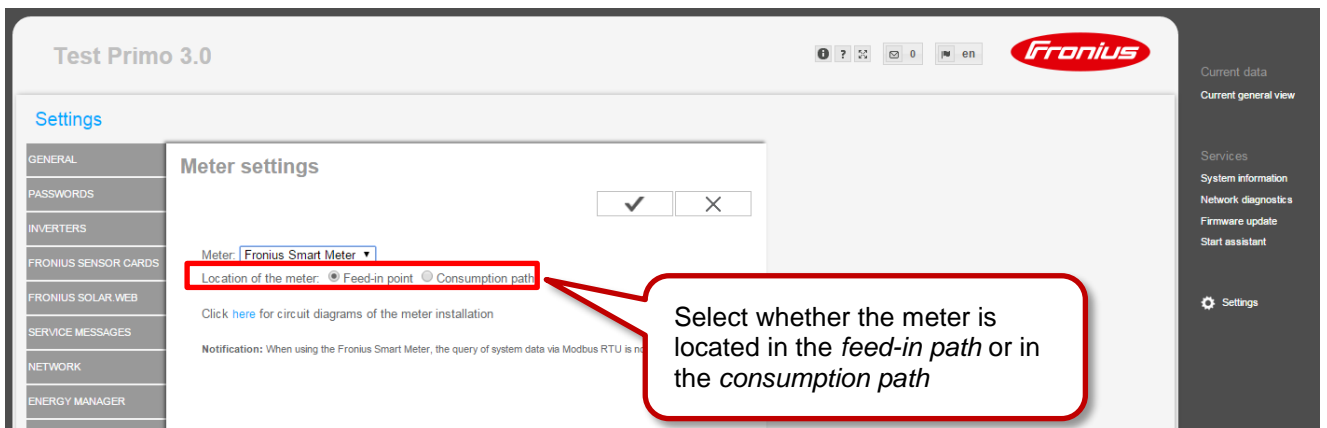

The meter is activated once you get the following message.

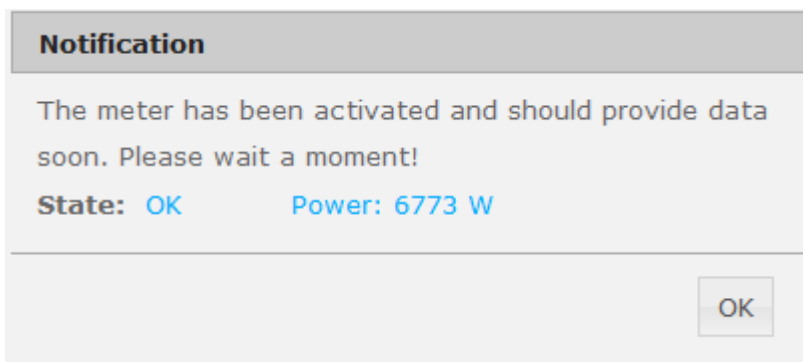

For more information on the Fronius Datamanager 2.0 please see the Operating Instructions on the Fronius website under *Solar Energy / Products / System monitoring / Datalogging /Fronius Datamanager 2.0* or click: http://www.fronius.com/cps/rde/xbcr/SID-DBD64F5C-18F6818F/fronius_australia/42_0426_0191_EA_388899_snapshot.pdf